

State of Nebraska - INVITATION TO BID CONTRACT

Date	12/14/22	Page	1 of 3
Solicitation Number	6746 OF		
Opening Date and Time	01/04/23	2:00 pm	
Buyer	CHRISTIE KELLY (AS)		

DESTINATION OF GOODS
DEPARTMENT OF TRANSPORTATION
5001 S 14TH ST
PO BOX 94759
LINCOLN NE 68509-4759

Per Nebraska's Transparency in Government Procurement Act, DAS is required to collect statistical information regarding the number of contracts awarded to Nebraska contractors. This information is for statistical purposes only and will not be considered for contract award purposes.

HW NEBRASKA CONTRACTOR AFFIDAVIT: Bidder hereby attests that bidder is a Nebraska Contractor. "Nebraska Contractor" shall mean any bidder who has maintained a bona fide place of business and at least one employee within this state for at least the six (6) months immediately preceding the posting date of this ITB.

HW I hereby certify that I am a Resident disabled veteran or business located in a designated enterprise zone in accordance with Neb. Rev. Stat. §73-107 and wish to have preference, if applicable, considered in the award of this contract.

Contract to supply and deliver ARTICULATED AWD LOADERS WITH MINIMUM 2.7 CY BUCKETS to the State of Nebraska as per the attached specifications for a one (1) year period from date of award. The contract may be renewed for four (4) additional one (1) year periods when mutually agreeable to the vendor and the State of Nebraska.

(12/12/22 sc)

INVITATION

Line	Description	Quantity	Unit of Measure	Unit Price	Extended Price
1	ARTICULATED AWD LOADER WITH MINIMUM 2.7 CY BUCKET BRAND: <u>John Deere</u> MODEL: <u>544 G</u> OPTIONAL ITEMS:	5.0000	EA	<u>\$ 179,100.⁰⁰</u>	<u>\$ 895,500.⁰⁰</u>
2	QUICK HITCH WITH SPECIFIED BUCKET	5.0000	EA	<u>\$ 9,510.⁰⁰</u>	<u>\$ 47,550.⁰⁰</u>

BIDDER MUST COMPLETE THE FOLLOWING

DISCOUNT PAYMENT TERMS: 0 % 30 DAYS

By signing this Invitation to Bid form, the bidder guarantees compliance with the provisions stated in this Invitation to Bid, agrees to the terms and conditions unless otherwise agreed to and certifies that bidder maintains a drug free work place environment. Vendor will furnish the items requested within 180 days after receipt of order. Failure to enter Delivery Date may cause quotation to be REJECTED.

Sign [Signature]
Here (Authorized Signature Mandatory - Form must be signed manually in ink or by DocuSign)

Enter Contact Information Below

VENDOR# _____
VENDOR: Murphy Tractor & Equipment
Address: 600 Arbor Rd
Lincoln NE 68517

Contact Herb Walkenhauer
Telephone 402 853 4870
Email h.walkenhauer@murphy-tractor.com

State of Nebraska - INVITATION TO BID CONTRACT

Date	12/14/22	Page	2 of 3
Solicitation Number	6746 OF		
Opening Date and Time	01/04/23	2:00 pm	
Buyer	CHRISTIE KELLY (AS)		

DESTINATION OF GOODS
 DEPARTMENT OF TRANSPORTATION
 5001 S 14TH ST
 PO BOX 94759
 LINCOLN NE 68509-4759

INVITATION

Line	Description	Quantity	Unit of Measure	Unit Price	Extended Price
	BRAND: <u>John Deere</u>				
	MODEL: <u>B4T10591</u>				
3	QUICK ATTACH FORKLIFT ASSEMBLY	5.0000	EA	<u>\$12,600.⁰⁰</u>	<u>\$63,000.⁰⁰</u>
	BRAND: <u>John Deere</u>				
	MODEL: <u>B4T10663</u>				
4	MULTI PURPOSE BUCKET	5.0000	EA	<u>\$17,300.⁰⁰</u>	<u>\$86,500.⁰⁰</u>
	BRAND: <u>TAG</u>				
	MODEL: <u>WL 2.75</u>				
5	GRAPPLE FORK ATTACHMENT	5.0000	EA	<u>\$13,750.⁰⁰</u>	<u>\$68,750.⁰⁰</u>
	BRAND: <u>GrabTec</u>				
	MODEL: <u>GA905</u>				
6	THIRD VALVE WITH LINES TO THE FRONT OF THE LOADER BOOM FOR ATTACHMENTS.	5.0000	EA	<u>In Base</u>	<u>In Base</u>
	BRAND: <u>John Deere</u>				
	MODEL: <u>7054</u>				
7	AM FM RADIO	5.0000	EA	<u>In Base</u>	<u>In Base</u>
8	WHEEL LOADER SCALE SYSTEM	5.0000	EA	<u>\$9,464.⁰⁰</u>	<u>\$47,320.⁰⁰</u>
	BRAND: <u>Weighlog</u>				
	MODEL: <u>8000T</u>				
9	WHEEL LOADER SCALE SYSTEM WITH IN CAB PRINTER	5.0000	EA	<u>\$1,090.⁰⁰</u>	<u>\$5,450.⁰⁰</u>
	BRAND: <u>Weighlog</u>				

State of Nebraska - INVITATION TO BID CONTRACT

Date	12/14/22	Page	3 of 3
Solicitation Number	6746 OF		
Opening Date and Time	01/04/23	2:00 pm	
Buyer	CHRISTIE KELLY (AS)		

DESTINATION OF GOODS
 DEPARTMENT OF TRANSPORTATION
 5001 S 14TH ST
 PO BOX 94759
 LINCOLN NE 68509-4759

INVITATION

Line	Description	Quantity	Unit of Measure	Unit Price	Extended Price
	MODEL: <u>ICP 300</u>				
10	EXTENDED WARRANTY AFTER THE FIRST YEAR OF THE BASIC WARRANTY EXPIRES. (DEDUCT)	5.0000	EA	<u><-2,000.00></u>	<u><-10,000.00></u>
11	TRANSPORTATION COSTS DURING THE EXTENDED WARRANTY PROGRAM IF NEEDED, NDOT WILL TAKE RESPONSIBILITY FOR THE DELIVERY OF THE LOADER TO A REPAIR FACILITY FOR THE EXTENDED WARRANTY PERIOD. (DEDUCT)	5.0000	EA	<u><-2,000.00></u>	<u><-10,000.00></u>
12	DELUXE AIR RIDE SEATS	5.0000	EA	<u>IN BASE</u>	<u>IN BASE</u>
	BRAND: <u>John Deere</u>				
	MODEL: <u>AIR RIDE</u>				

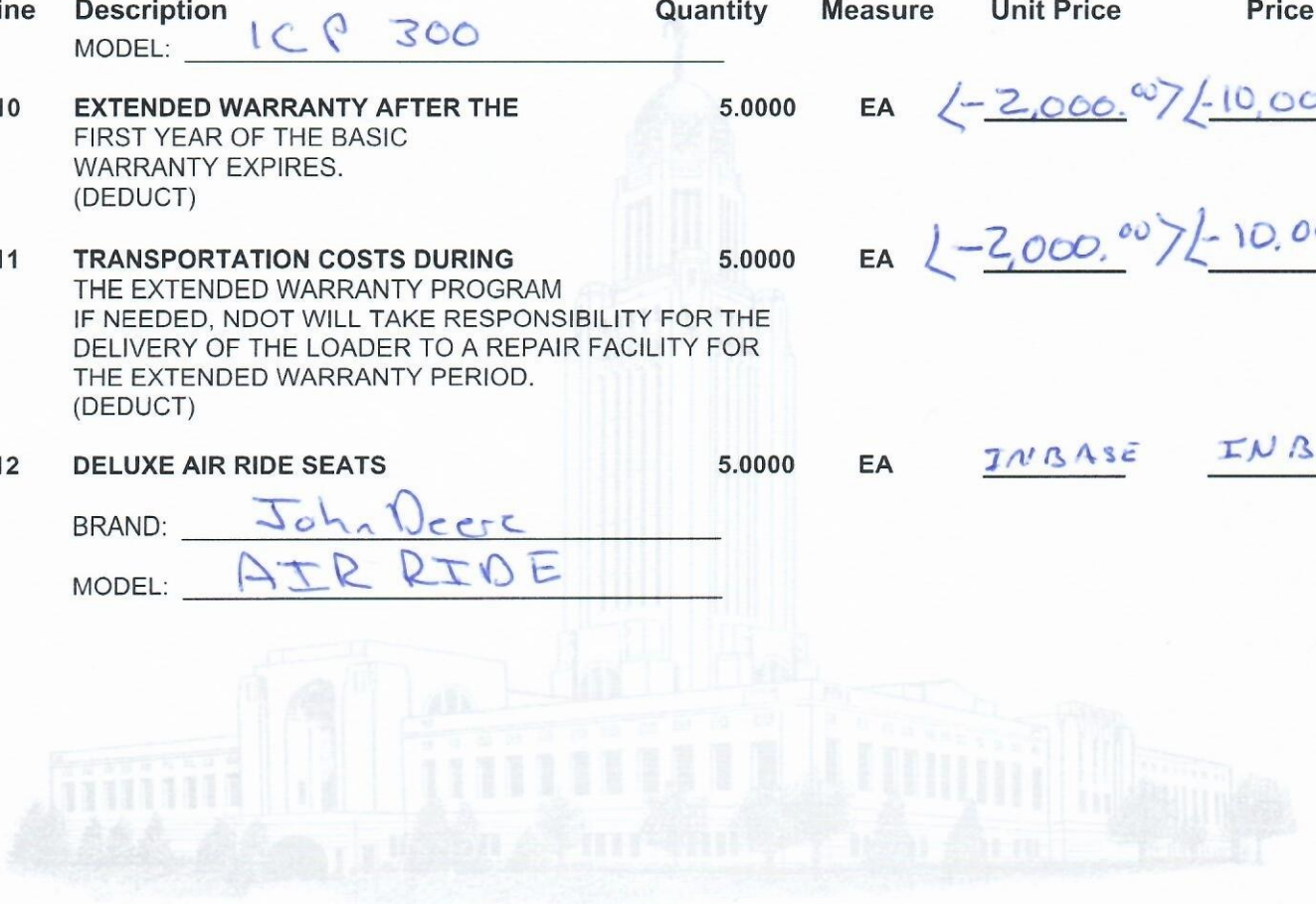

**ARTICULATED ALL WHEEL DRIVE (AWD) LOADER
WITH MINIMUM 2.7 CUBIC YARD (CY) BUCKET
STATE OF NEBRASKA/NDOT
INVITATION TO BID
6746 OF**

The State of Nebraska (State), Department of Administrative Services (DAS), Materiel Division, State Purchasing Bureau (SPB), is issuing this bid for a commodity contract, ITB Number 6746 OF for the purpose of selecting a qualified Bidder to provide **Articulated All Wheel Drive Loader with Minimum 2.7 Cubic Yard Bucket**. A more detailed description can be found in Sections II through VII. The resulting contract may not be an exclusive contract as the State reserves the right to contract for the same or similar goods from other sources now or in the future.

INFORMATION PERTINENT TO THIS BID CAN BE FOUND ON THE INTERNET AT:

<http://das.nebraska.gov/materiel/purchasing.html>

PUBLIC POSTING NOTICE:

Pursuant to the Taxpayer Transparency Act (Neb. Rev. Stat. §§ 84-602.01 to 84-602.04) and in furtherance of public records statutes (Neb. Rev. Stat. § 84-712 et seq.), State contracts, must be posted to a public website. The resulting Contract, the ITB, and the successful Bidder's entire bid and response will be posted to a public website managed by DAS, which can be found at:

<https://statecontracts.nebraska.gov> & https://www.nebraska.gov/das/materiel/purchasing/contract_search/index.php

If the Bidder wishes to withhold proprietary or other commercial information from disclosure, the Bidder must do the following:

- a. Identify the Proprietary Information;
- b. Mark the Proprietary Information; and
- c. Submit the Proprietary Information under separate cover marked clearly using an indelible method with the words **"PROPRIETARY INFORMATION"**.
- d. The mere assertion that information is Proprietary or that a speculative Business advantage might be gained is not sufficient. (See Attorney General Opinion No. 92068, April 27, 1992). **THE BIDDER MAY NOT ASSERT THAT THE ENTIRE BID IS PROPRIETARY. COST WILL NOT BE CONSIDERED PROPRIETARY AND IS A PUBLIC RECORD SUBJECT TO DISCLOSURE.**
The State may require a Bidder to submit more information, including, but not limited to, a detailed explanation as to how and why the designated information is Proprietary.

The State will determine, in its sole discretion, if the disclosure of the designated Proprietary Information would:

- a. Give advantage to Business competitors; and
- b. Serve no public purpose.

Absent a determination by the State that the information may be withheld pursuant to Neb. Rev. Stat. § 84-712.05, the State will consider all information a public record subject to disclosure.

In the event that disclosure of Proprietary Information is ordered or requested, it will be the Bidder's responsibility to assert and defend the non-disclosure.

To facilitate public postings, with the exception of Proprietary Information, the State reserves a royalty-free, nonexclusive, and irrevocable right to copy, reproduce, publish, post to a website, or otherwise use any contract, bid, or response to this ITB for any purpose, and to authorize others to use the documents. Any individual or entity Awarded a contract, or who submits a bid in response to this ITB, specifically waives any Copyright or other protection the contract, bid, or response to the ITB may have; and acknowledges that they have the ability and authority to enter into such waiver. This reservation and waiver are a prerequisite for submitting a bid or response to this ITB, and Award of a contract. Failure to agree to the reservation and waiver will result in the bid being found non-responsive and rejected.

Any entity Awarded a contract or submitting a bid or response to the ITB agrees not to sue, file a claim, or make a demand of any kind, and will indemnify and hold harmless the State and its employees, volunteers, Agents, and its elected and appointed officials from and against any and all claims, liens, demands, damages, liability, actions, causes of action, losses, judgments, costs, and expenses of every nature, including investigation costs and expenses, settlement costs, and attorney fees and expenses, sustained or asserted against the State, arising out of, resulting from, or attributable to the posting of the contract or the bids and responses to the ITB, Awards, and other documents.

TABLE OF CONTENTS

TABLE OF CONTENTS.....	ii
GLOSSARY OF TERMS.....	iv
ACRONYM LIST.....	viii
I. PROCUREMENT PROCEDURE	1
A. GENERAL INFORMATION.....	1
B. PROCURING OFFICE AND COMMUNICATION WITH STATE STAFF AND EVALUATORS.....	1
C. SCHEDULE OF EVENTS.....	1
D. WRITTEN QUESTIONS AND ANSWERS.....	2
E. SECRETARY OF STATE/TAX COMMISSIONER REGISTRATION REQUIREMENTS (Statutory).....	2
F. ETHICS IN PUBLIC CONTRACTING.....	2
G. DEVIATIONS FROM THE ITB.....	2
H. SUBMISSION OF BIDS.....	2
I. BID PREPARATION COSTS.....	3
J. FAILURE TO COMPLY WITH ITB.....	3
K. BID CORRECTIONS.....	4
L. LATE BIDS.....	4
M. BID OPENING.....	4
N. ITB REQUIREMENTS.....	4
O. EVALUATION OF BIDS.....	4
P. BEST AND FINAL OFFER.....	5
Q. REFERENCE AND CREDIT CHECKS.....	5
R. AWARD.....	5
S. DISCOUNTS.....	5
T. PRICES.....	5
U. SPECIFICATIONS.....	6
V. ALTERNATE/EQUIVALENT BIDS.....	6
W. "LUMP SUM" OR "ALL OR NONE" BIDS.....	6
X. EMAIL SUBMISSIONS.....	6
Y. BID TABULATIONS.....	6
Z. REJECTION OF BIDS.....	6
AA. RESIDENT BIDDER.....	6
II. TERMS AND CONDITIONS	7
A. GENERAL.....	7
B. NOTIFICATION.....	7
C. PCO REPRESENTATIVE.....	7
D. GOVERNING LAW (Statutory).....	8
E. AMENDMENT.....	8
F. SUBSTITUTIONS.....	8
G. VENDOR PERFORMANCE REPORT(S).....	8
H. NOTICE OF POTENTIAL BIDDER BREACH.....	8
I. BREACH.....	9
J. NON-WAIVER OF BREACH.....	9
K. SEVERABILITY.....	9
L. INDEMNIFICATION.....	9
M. ATTORNEY'S FEES.....	10
N. ASSIGNMENT, SALE, OR MERGER.....	10
O. CONTRACTING WITH OTHER POLITICAL SUB-DIVISIONS OF THE STATE OR ANOTHER STATE.....	10
P. FORCE MAJEURE.....	11
Q. CONFIDENTIALITY.....	11
R. EARLY TERMINATION.....	11
III. BIDDER DUTIES	13
A. INDEPENDENT BIDDER / OBLIGATIONS.....	13
B. EMPLOYEE WORK ELIGIBILITY STATUS.....	13
C. COMPLIANCE WITH CIVIL RIGHTS LAWS AND EQUAL OPPORTUNITY EMPLOYMENT / NONDISCRIMINATION (Statutory).....	14
D. COOPERATION WITH OTHER BIDDERS.....	14
E. COST CLARIFICATION.....	14
F. PERMITS, REGULATIONS, LAWS.....	14
G. NOTICE OF POTENTIAL BIDDER BREACH.....	14

H.	ANTITRUST	14
I.	CONFLICT OF INTEREST	15
J.	ADVERTISING	15
K.	NEBRASKA TECHNOLOGY ACCESS STANDARDS (Statutory)	15
L.	DISASTER RECOVERY/BACK UP PLAN	15
M.	DRUG POLICY	15
N.	WARRANTY	16
IV.	PAYMENT	17
A.	PROHIBITION AGAINST ADVANCE PAYMENT (Statutory)	17
B.	TAXES (Statutory)	17
C.	INVOICES	17
D.	INSPECTION AND APPROVAL	17
E.	PAYMENT (Statutory)	17
F.	LATE PAYMENT (Statutory)	17
G.	SUBJECT TO FUNDING / FUNDING OUT CLAUSE FOR LOSS OF APPROPRIATIONS (Statutory)	17
H.	RIGHT TO AUDIT (First Paragraph is Statutory)	17
V.	SCOPE OF WORK	19
A.	SCOPE	19
VI.	TECHNICAL SPECIFICATIONS	20
A.	BIDDER INSTRUCTIONS	20
B.	NON-COMPLIANCE STATEMENT	20
C.	ENGINE	20
D.	DRIVE 21	20
E.	TIRES AND WHEELS	21
F.	BRAKES	21
G.	STEERING	22
H.	LOADER	22
I.	CAB 22	22
J.	INSTRUMENTS	23
K.	HYDRAULIC SYSTEM	23
L.	COUNTERWEIGHTS	24
M.	GENERAL	24
N.	NOISE LEVEL	24
O.	RADIO FREQUENCY SHIELDING – CAUTION!!!	24
P.	MANUALS	25
Q.	MISCELLANEOUS	26
R.	TRAINING	26
S.	SPECIFICATION FORM(S)	26
T.	ANNUAL USAGE, ESTIMATED	27
U.	USAGE REPORT	27
V.	DELIVERY ARO	27
W.	DELIVERY LOCATION	27
X.	ORDERS	27
Y.	QUALITY	28
Z.	WARRANTY	28
AA.	AUTHORIZED DEALER & WARRANTY	29
VII.	OPTIONS	30
A.	QUICK HITCH WITH SPECIFIED BUCKET	30
B.	QUICK ATTACH FORKLIFT ASSEMBLY	30
C.	MULTI-PURPOSE BUCKET	30
D.	GRAPPLE FORK ATTACHMENT	31
E.	WHEEL LOADER SCALE SYSTEM	31

GLOSSARY OF TERMS

Acceptance Test Procedure: Benchmarks and other performance criteria, developed by the State or other sources of testing standards, for measuring the effectiveness of products or goods and the means used for testing such performance

Addendum: Something to be added or deleted to an existing document; a supplement

Agency: Using agencies shall mean and include all officers of the state, departments, bureaus, boards, commissions, councils, and institutions receiving legislative appropriations

Agent/Representative: A person authorized to act on behalf of another

Amend: To alter or change by adding, subtracting, or substituting

Amendment: A written correction or alteration to a document

Appropriation: Legislative authorization to expend public funds for a specific purpose. Money set apart for a specific use

Automated Clearing House: Electronic network for financial transactions in the United States

Award: All purchases, leases, or contracts which are based on competitive bids will be awarded according to the provisions in the bid

Best and Final Offer: In a competitive bid, the final offer submitted which contains bidder's most favorable terms for price

Bidder: A contractor who submits an offer bid in response to a written solicitation

Breach: Violation of a contractual obligation by failing to perform or repudiation of one's own promise.

Business Day: Any weekday, except State-recognized holidays

Calendar Day: Every day shown on the calendar including Saturdays, Sundays, and State/Federal holidays

Cancellation: To call off or revoke a bid, purchase order or contract without expectation of conducting or performing at a later time

Central Processing Unit: Any computer or computer system that is used by the State to store, process, or retrieve data or perform other functions using Operating Systems and applications software

Collusion: An agreement or cooperation between two (2) or more persons or entities to accomplish a fraudulent, deceitful, or unlawful purpose

Commodities: Any equipment, material, supply, or goods; anything movable or tangible that is provided or sold

Commodities Description: Detailed descriptions of the items to be purchased, may include information necessary to obtain the desired quality, type, color, size, shape, or special characteristics necessary to perform the work intended to produce the desired results

Competition: The effort or action of two or more commercial interests to obtain the same business from third parties

Confidential Information: Unless otherwise defined below, "Confidential Information" shall also mean proprietary trade secrets, academic and scientific research work which is in progress and unpublished, and other information which if released would give advantage to business competitors and serve no public purpose (see Neb. Rev. Stat. §84-712.05(3)). In accordance with Nebraska Attorney General Opinions 92068 and 97033, proof that information is proprietary requires identification of specific, named competitor(s) who would be advantaged by release of the information and the specific advantage the competitor(s) would receive

Contract: An agreement between two (2) or more parties creating obligations that are enforceable or otherwise recognizable at law; the writing that sets forth such an agreement

Contract Administration: The management of the contract which includes and is not limited to contract signing, contract amendments and any necessary legal actions

Contract Management: The management of day-to-day activities at the agency which includes and is not limited to ensuring deliverables are received, specifications are met, handling meetings, and making payments to the Bidder

Contract Period: The duration of the contract

Contractor: An individual or entity lawfully conducting business in the State, who seeks or agrees to provide goods or services under the terms of a written contract.

Cooperative Purchasing: The combining of requirements of two or more political entities to obtain advantages of volume purchases, reduction in administrative expenses or other public benefits

Copyright: A property right in an original work of authorship fixed in any tangible medium of expression, giving the holder the exclusive right to reproduce, adapt and distribute the work

Critical Program Error: Any Program Error, whether or not known to the State, which prohibits or significantly impairs use of the Licensed Software as set forth in the documentation and intended in the contract

Customer Service: The process of ensuring customer satisfaction by providing assistance and advice on those products or goods provided by a Bidder

Default: The omission or failure to perform a contractual duty

Deviation: Any proposed change(s) or alteration(s) to either the terms and conditions or deliverables within the scope of the written bid or contract

Evaluation: The process of examining an offer after opening to determine the bidder's responsibility, responsiveness to requirements, and to ascertain other characteristics of the offer that relate to determination of the successful award

Evaluator: Agency individual(s) that advises and assists the procuring office in the evaluation of bids.

Extension: Continuance of a contract for a specified duration upon the agreement of the parties beyond the original Contract Period. Not to be confused with "Renewal Period"

Free on Board Destination: The delivery charges are included in the quoted price and prepaid by the bidder. Bidder is responsible for all claims associated with damages during delivery of product

Foreign Corporation: A foreign corporation that was organized and chartered under the laws of another state, government, or country.

Grievance: A complaint about a governmental action or decision related to the bid or resultant contract, brought by a bidder who has timely submitted a bid response in connection with the award in question, to AS Materiel Division or another designated agency with the intention of achieving a remedial result.

Installation Date: The date when the procedures described in "Installation by Contractor", and "Installation by State", as found in the solicitation, or contract are completed.

Interested Party: A person, acting in their personal capacity, or an entity entering into a contract or other agreement creating a legal interest therein

Invalid Bid: A bid that does not meet the requirements of the bid or cannot be evaluated against the other bids.

Invitation to Bid: A written bid utilized for obtaining competitive offers for Services or Goods

Late Bid: An offer received after the Opening Date and Time

Licensed Software Documentation: The user manuals and any other materials in any form or medium customarily provided by the Bidder to the users of the Licensed Software which will provide the State with sufficient information to operate, diagnose, and maintain the Licensed Software properly, safely, and efficiently

Mandatory: Required, compulsory, or obligatory

May: Discretionary, permitted; used to express possibility

Module (see System): A collection of routines and data structures that perform a specific function of software

Must: See "Mandatory"

National Institute for Governmental Purchasing: Source used for assignment of universal commodity codes to goods and services

Open Market Purchase: Authorization may be given to an agency to purchase items above direct purchase authority due to the unique nature, price, quantity, location of the using agency, or time limitations by the AS Materiel Division, State Purchasing Bureau

Opening Date and Time: Specified date and time for the public opening of received, labeled, and sealed formal bids

Operating System: The control program in a computer that provides the interface to the computer hardware and peripheral devices, and the usage and allocation of memory resources, processor resources, input/output resources, and security resources

Outsourcing: The contracting out of a business process which an organization may have previously performed internally or has a new need for, to an independent organization from which the process is purchased back

Payroll & Financial Center: Electronic procurement system of record

Platform: A specific hardware and Operating System combination that is different from other hardware and Operating System combinations to the extent that a different version of the Licensed Software product is required to execute properly in the environment established by such hardware and Operating System combination

Point of Contact: The person designated to receive communications and to communicate

Product: Something that is distributed commercially for use or consumption and that is usually (1) tangible personal property, (2) the result of fabrication or processing, and (3) an item that has passed through a chain of commercial distribution before ultimate use or consumption

Program Error: Code in Licensed Software which produces unintended results or actions, or which produces results or actions other than those described in the specifications. A program error includes, without limitation, any Critical Program Error

Program Set: The group of programs and products, including the Licensed Software specified in the bid, plus any additional programs and products licensed by the State under the contract for use by the State

Project: The total scheme, program, or method worked out for the accomplishment of an objective, including all documentation, commodities, and goods to be provided under the contract

Proposal: An offer, bid, or quote submitted by a contractor/vendor in a response to a written solicitation

Proprietary Information: Proprietary information is defined as trade secrets, academic and scientific research work which is in progress and unpublished, and other information which if released would give advantage to business competitors and service no public purpose (see Neb. Rev. Stat. § 84-712.05(3)). In accordance with Attorney General Opinions 92068 and 97033, proof that information is proprietary requires identification of specific named competitor(s) advantaged by release of the information and the demonstrated advantage the named competitor(s) would gain by the release of information

Protest: See "Grievance"

Public Bid Opening: The process of opening correctly submitted offers at the time and place specified in the written bid and in the presence of anyone who wished to attend

Quote: See Bid

Recommended Hardware Configuration: The data processing hardware (including all terminals, auxiliary storage, communication, and other peripheral devices) to the extent utilized by the State as recommended by the Bidder.

Release Date: The date of public release of the written bid to seek offers

Renewal Period: Optional contract periods subsequent to the original Contract Period for a specified duration with previously agreed to terms and conditions. Not to be confused with Extension

Request for Information: A general invitation to bidder is requesting information for a potential future bid. The RFI is typically used as a research and information gathering tool for preparation of a bid

Responsible Bidder: A Bidder who has the capability in all respects to perform fully and lawfully all requirements with integrity and reliability to assure good faith performance

Responsive Bidder: A Bidder who has submitted a bid which conforms to all requirements of the bid document

Shall: See "Mandatory"

Should: Expected; suggested, but not necessarily mandatory

Software License: Legal instrument with or without printed material that governs the use or redistribution of licensed software

Specifications: The detailed statement, especially of the measurements, quality, materials, and functional characteristics, or other items to be provided under a contract

Statutory: These clauses are controlled by state law and are not subject to negotiation

Subcontractor: Individual or entity with whom the bidder enters a contract to perform a portion of the work awarded to the bidder

System (see Module): Any collection or aggregation of two (2) or more Modules that is designed to function, or is represented by the Bidder as functioning or being capable of functioning, as an entity

Termination: Occurs when the contract expires or either party, pursuant to a power created by agreement or law puts an end to the contract prior to the stated expiration date. All obligations which are still executory on both sides are discharged but any right based on prior breach or performance survives

Third-Party: Any person or entity, including but not limited to fiduciaries, shareholders, owners, officers, managers, employees, legally disinterested persons, and sub-contractors or agents, and their employees. It shall not include any entity or person who is an interested Party to the contract or agreement

Trade Secret: Information, including, but not limited to, a drawing, formula, pattern, compilation, program, device, method, technique, code, or process that (a) derives independent economic value, actual or potential, from not being known to, and not being ascertainable by proper means by, other persons who can obtain economic value from its disclosure or use; and (b) is the subject of efforts that are reasonable under the circumstances to maintain its secrecy (see Neb. Rev. Stat. § 87-502(4))

Trademark: A word, phrase, logo, or other graphic symbol used by a manufacturer or bidder to distinguish its product from those of others, registered with the U.S. Patent and Trademark Office

Upgrade: Any change that improves or alters the basic function of a product of service

Vendor Performance Report: A report completed by the using agency and submitted to State Purchasing Bureau documenting products or services delivered or performed which exceed or fail to meet the terms of the purchase order, contract, and/or bid specifications.

Vendor: Inclusive term for any Bidder or Contractor.

Will: See "Mandatory"

ACRONYM LIST

AC: Alternating Current
ACH: Automated Clearing House
ARO: After Receipt of Order
AWD: All Wheel Drive
BAFO: Best and Final Offer
CY: Cubic Yard
DAS: Department of Administrative Services
DBA: A Weighted Decibel
FOB: Free on Board
ISO: International Organization for Standardization
ITB: Invitation to Bid
LED: Light Emitting Diode
MHz: Megahertz
MPH: Miles Per Hour
NDOT: Nebraska Department of Transportation
NIGP: National Institute for Governmental Purchasing
OEM: Original Equipment Manufacturer
OSHA: Occupational Safety and Health Administration
PCO: Procurement Contracts Officer
POC: Point of Contact
PSI: Pounds per Square Inch
RFI: Request for Information
ROPS: Rollover Protection Structure
SAE: Society of Automotive Engineers
SPB: State Purchasing Bureau
UHF: Ultra High Frequency
VHF: Very High Frequency

I. PROCUREMENT PROCEDURE

A. GENERAL INFORMATION

The bid is designed to solicit bids from qualified Bidders who will be responsible for providing **Articulated AWD Loader with Minimum 2.7 CY Bucket** at a competitive and reasonable cost. Terms and Conditions, Project Description and Scope of Work, Bid instructions, and Cost Bid Requirements may be found in Sections II through VII.

Bids shall conform to all instructions, conditions, and requirements included in the bid. Prospective Bidders are expected to carefully examine all documents, schedules, and requirements in this bid, and respond to each requirement in the format prescribed. Bids may be found non-responsive if they do not conform to the bid.

B. PROCURING OFFICE AND COMMUNICATION WITH STATE STAFF AND EVALUATORS

Procurement responsibilities related to this bid reside with SPB. The POC for the procurement is as follows:

Name: Christie Kelly, PCO
 Agency: State Purchasing Bureau
 Address: 1526 K Street, Suite 130
 Lincoln, NE 68508

Telephone: 402-471-6500

E-Mail: as.materielpurchasing@nebraska.gov

From the date the bid is issued until the Intent to Award is issued, communication from the Bidder is limited to the POC listed above. After the Intent to Award is issued, the Bidder may communicate with individuals the State has designated as responsible for negotiating the contract on behalf of the State. No member of the State Government, employee of the State, or member of the Evaluation Committee is empowered to make binding statements regarding this bid. The POC will issue any answers, clarifications, or amendments regarding this bid in writing. Only the SPB or awarding agency can award a contract. Bidders shall not have any communication with or attempt to communicate or influence any evaluator involved in this bid.

The following exceptions to these restrictions are permitted:

1. Contact made pursuant to pre-existing contracts or obligations;
2. Contact required by the schedule of events, or an event scheduled later by POC; and
3. Contact required for negotiation and execution of the final contract.

The State reserves the right to reject a bidder's bid, withdraw an Intent to Award, or terminate a contract if the State determines there has been a violation of these procurement procedures.

C. SCHEDULE OF EVENTS

The State expects to adhere to the procurement schedule shown below, but all dates are approximate and subject to change.

	ACTIVITY	DATE/TIME
1.	Release ITB	December 14, 2022
2.	Last day to submit written questions. Upload written questions for 6742 OF electronically via ShareFile to: https://nebraska.sharefile.com/r-r8841af42a7b848e89cc26fcfa0545389	December 21, 2022
3.	State responds to written questions through an Addendum to be posted to the Internet at: https://das.nebraska.gov/materiel/bidopps.html#	December 28, 2022
4.	Electronic Bid Opening via Zoom Electronically submitted bids are being accepted due to the challenges of COVID-19. Upload electronic Bid submissions for 6742 OF via ShareFile to: https://nebraska.sharefile.com/r-ra01b89aa23af4762959ad94cba249e04 Zoom Meeting Information: https://us02web.zoom.us/j/7318536781?pwd=cHRFNDDJzRzBwSitiVDZSQytEa2Zwdz09 Meeting ID: 731 853 6781 Passcode: 4Gkv2t	January 4, 2023 2:00 PM Central Time

D. WRITTEN QUESTIONS AND ANSWERS

Questions regarding the meaning or interpretation of any bid provision must be submitted in writing to SPB and clearly marked "ITB Number 6742 OF; **Articulated AWD Loader with Minimum 2.7 CY Bucket Questions**". POC is not obligated to respond to questions that are received late per the Schedule of Events.

Questions should be uploaded to ShareFile at <https://nebraska.sharefile.com/r-r8841af42a7b848e89cc26fcfa0545389> but may also be emailed.

The Bidder Should present, as questions, any assumptions upon which the Bidder's bid is or might be developed. Bids will be evaluated without consideration of any known or unknown assumptions. The Contract will NOT incorporate any known or unknown assumptions.

It is recommended that questions be submitted using the following format:

Bid Section Reference	Bid Page Number	Question

Written answers will be posted at <http://das.nebraska.gov/materiel/purchasing.html> per the Schedule of Events.

E. SECRETARY OF STATE/TAX COMMISSIONER REGISTRATION REQUIREMENTS (Statutory)

All Bidders must be authorized to transact business in the State and comply with all Nebraska Secretary of State Registration requirements. The Bidder who is the recipient of an Intent to Award will be required to certify that it has complied and produce a true and correct copy of its current (within ninety (90) calendar days of the intent to award) Certificate or Letter of Good Standing, or in the case of a sole proprietorship, provide written documentation of sole proprietorship and the United States Citizenship Attestation Form, available on the DAS website at: <http://das.nebraska.gov/materiel/purchasing.html>. This must be accomplished prior to execution of the contract.

F. ETHICS IN PUBLIC CONTRACTING

The State reserves the right to reject bids, withdraw an intent to award or award, or terminate a contract if a Bidder commits or has committed ethical violations, which include, but are not limited to:

1. Offering or giving, directly or indirectly, a bribe, fee, commission, compensation, gift, gratuity, or anything of value to any person or entity in an attempt to influence the bidding process;
2. Utilize the services of lobbyists, attorneys, political activists, or consultants to influence or subvert the bidding process;
3. Being considered for, presently being, or becoming debarred, suspended, ineligible, or excluded from contracting with any state or federal entity;
4. Submitting a bid on behalf of another party or entity;
5. Collude with any person or entity to influence the bidding process, submit sham bids, preclude bidding, fix pricing or costs, create an unfair advantage, subvert the bid, or prejudice the State.

The Bidder shall include this clause in any subcontract entered into for the exclusive purpose of performing this contract.

Bidder shall have an affirmative duty to report any violations of this clause by the Bidder throughout the bidding process, and throughout the term of this contract for the successful Bidder and their subcontractors.

G. DEVIATIONS FROM THE ITB

The requirements contained in the bid (Sections II through VII) become a part of the terms and conditions of the contract resulting from this bid. Any deviations from the bid in Sections II through VII must be clearly defined by the Bidder in its bid and, if accepted by the State, will become part of the contract. Any specifically defined deviations must not be in conflict with the basic nature of the bid, bid requirements, or applicable state or federal laws or statutes. "Deviation", for the purposes of this bid, means any proposed changes or alterations to either the contractual language or deliverables within the scope of this bid. The State discourages deviations and reserves the right to reject proposed deviations.

H. SUBMISSION OF BIDS

The State is accepting electronically submitted bids for this ITB.

IT IS THE BIDDERS' RESPONSIBILITY TO ENSURE ALL BIDS SHALL BE SUBMITTED AND RECEIVED BY THE DATE AND TIME INDICATED IN THE SCHEDULE OF EVENTS FOR EACH BID SUBMITTED.

All bids must be received by SPB by the date and time of the Bid Opening per the Schedule of Events. It is the Bidder's responsibility to ensure timely submission and receipt and the State is not responsible for bids that are late or lost, regardless of cause or fault. No Late Bids will be evaluated.

Late Bids may be returned to the bidder if requested by the Bidder within sixty (60) Calendar days after this late bid was submitted and will at the Bidder's expense.

1. **ELECTRONICALLY SUBMITTING ELECTRONIC BID(S)**
 - a. Bidders should upload bid(s) via ShareFile to: <https://nebraska.sharefile.com/r-ra01b89aa23af4762959ad94cba249e04>
 - b. Not all browsers are compatible with ShareFile. Currently Chrome, Internet Explorer and Firefox are compatible, but Microsoft Edge is not.
 - c. **After the bidder clicks the bid submission link, the bidder will be prompted to enter contact information including an e-mail address so that the bidder will receive a confirmation email confirming the successful upload directly from ShareFile.**
 - d. The Bidder is solely responsible for any variance between the copies submitted.
 - e. If multiple bids are submitted, the State will retain only the most recently submitted response.
2. **OTHER BID DOCUMENTS TO UPLOAD TO SHAREFILE**
 - a. Any **Proprietary information** (if applicable) should be uploaded as separate and distinct files.
 - b. If it is the bidder's intent to submit multiple bids, the bidder must clearly identify each submission separately (see "Electronic ITB File Names" below).
 - c. It is the Bidder's responsibility to submit the Electronic Bid(s) and be received by the date and time of the Bid Opening indicated in the Schedule of Events.
 - d. **No late Bids will be accepted.**
 - e. **Hardware, software, internet, user, or electronic issues will not excuse a late bid.**
3. **ELECTRONIC ITB FILE NAMES**
 - a. The Bidder should clearly identify the uploaded Bid files.
 - b. **Do not submit bid file(s) more than 30 days prior to the Bid Opening. Once file(s) are uploaded they are only available for 30 days.**
 - c. **DO NOT ADD any language to the naming conventions below.** Long titles can make the files difficult to work with. Consistency is key.
 - d. If the bidder submits the bid/bid documents as **one (1) complete packet (preferred method)**, please use the following naming convention:
 - **6742 OF Articulated AWD Loader-Min 2.7 CY Bucket <<NAME OF BIDDER>> Bid.**
 - e. If the bidder submits the bid/bid documents as separate files, please use the following naming convention(s):
 - **6742 OF Articulated AWD Loader-Min 2.7 CY Bucket <<NAME OF BIDDER>> Bid.**
 - **6742 OF Articulated AWD Loader-Min 2.7 CY Bucket <<NAME OF BIDDER>> File 1, File 2, File 3, etc.....**
 - f. If multiple bids are submitted for the same ITB number, follow the same naming convention as letter "e", for example:
 - **6742 OF Articulated AWD Loader-Min 2.7 CY Bucket <<NAME OF BIDDER>> Bid 2, File 1, File 2, File 3, etc....**

The ITB document must be manually signed in an indelible manner or by DocuSign and returned by the Bid Opening Date and Time along with the Bidder's bid and any other required documents as stated in the ITB document in order for the Bidder's ITB to be evaluated.

It is the responsibility of the Bidder to check the website often for all information relevant to this ITB to include Addenda and/or Amendments issued prior to the Opening Date and Time. The website address is: <https://das.nebraska.gov/materiel/bidopps.html>

Emphasis Should be concentrated on conformance to the ITB. Bids Should be clear and complete. If the bid is not presented clearly or is difficult to discern, in the sole opinion of the State, the State reserves the right to reject the bid.

By signing the ITB, the Bidder guarantees compliance with the provisions stated in this ITB.

I. BID PREPARATION COSTS

The State shall not incur any liability for any costs incurred by Bidders in replying to this bid, including any activity related to bidding on this bid

J. FAILURE TO COMPLY WITH ITB

Violation of the terms and conditions contained in this bid or any resultant contract, at any time before or after the award, shall be grounds for action by the State which may include, but is not limited to, the following:

1. Rejection of a Bidder's bid;
2. Withdrawal of the Intent to Award;
3. Withdrawal of the Award;
4. Negative Bidder Performance Report(s)
5. Termination of the resulting contract,
6. Legal action; or,
7. Suspension of the Bidder from further bidding with the State for the period of time relative to the seriousness of the violation, such period to be within the sole discretion of the State.

K. BID CORRECTIONS

A bidder may correct a mistake in a bid prior to the time of opening by giving written notice to the State of intent to withdraw the bid for modification or to withdraw the bid completely. Changing a bid after opening may be permitted if the change is made to correct a minor error that does not affect price, quantity, quality, delivery, or contractual conditions. In case of a mathematical error in extension of price, unit price shall govern.

L. LATE BIDS

Bids received after the time and date of the bid opening will be considered late bids. Late bids will be returned unopened, if requested by the Bidder and at Bidder's expense. The State is not responsible for bids that are late or lost regardless of cause or fault.

M. BID OPENING

Anyone may attend the opening. It is considered a public opening. The Buyer will read the names of the respondents. Depending upon the complexity of the bid for goods, the buyer may read the bids aloud or allow bids to be available for viewing by the public during the bid opening. Once the bid opening has concluded, the bids will not be available for viewing until the Intent to Award has been posted. An initial bid tabulation will be posted to the website as soon as feasible. Information identified as proprietary by the submitting bidder, in accordance with the bid and state statute, will not be posted. If the state determines submitted information should not be withheld, in accordance with the [Public Records Act](#), or if ordered to release any withheld information, said information may then be released. The submitting bidder will be notified of the release and it shall be the obligation of the submitting bidder to take further action if it believes the information should not be released.

N. ITB REQUIREMENTS

The bids will first be examined to determine if all requirements listed below have been addressed and whether further evaluation is warranted. Bids not meeting the requirements may be rejected as non-responsive. The requirements are:

1. The original Commodity ITB document must be manually signed in an indelible manner or by DocuSign;
2. Clarity and responsiveness of the bid;
3. Completed Sections II through VII;
4. Completed ITB Form or State's Bid Sheet.

O. EVALUATION OF BIDS

All bids that are responsive to the bid will be evaluated based on the following:

Neb. Rev. Stat. § 81-161 allows the quality of performance of previous contracts to be considered when evaluating responses to competitively bid bids in determining the lowest responsible bidder. Information obtained from any Bidder Performance Report (See Terms & Conditions, Section H) may be used in evaluating responses to bids for goods and services to determine the best value for the State.

Neb. Rev. Stat. § 73-107 allows for a preference for a resident disabled veteran or business located in a designated enterprise zone. When a state contract is to be awarded to the lowest responsible bidder, a resident disabled veteran or a business located in a designated enterprise zone under the Enterprise Zone Act shall be allowed a preference over any other resident or nonresident bidder, if all other factors are equal.

Resident disabled veterans means any person (a) who resides in the State of Nebraska, who served in the United States Armed Forces, including any reserve component or the National Guard, who was discharged or otherwise separated with a characterization of honorable or general (under honorable conditions), and who possesses a disability rating letter issued by the United States Department of Veterans Affairs establishing a service-connected disability or a disability determination from the United States Department of Defense and (b)(i) who owns and controls a business or, in the case of a publicly owned business, more than fifty percent of the stock is owned by one or more persons described in subdivision (a) of this subsection and (ii) the management and daily business operations of the business are controlled by one or more persons described in subdivision(a) of this subsection. Any contract entered into without compliance with this section shall be null and void.

Therefore, if a resident disabled veteran or business located in a designated enterprise zone submits a bid in accordance with Neb. Rev. Stat. § 73-107 and has so indicated on the ITB cover page under "Bidder must complete the following" requesting priority/preference to be considered in the award of this contract, the following will need to be submitted by the bidder within ten (10) business days of request:

1. Documentation from the United States Armed Forces confirming service;
2. Documentation of discharge or otherwise separated characterization of honorable or general (under honorable conditions);
3. Disability rating letter issued by the United States Department of Veterans Affairs establishing a service-connected disability or a disability determination from the United States Department of Defense; and
4. Documentation which shows ownership and control of a business or, in the case of a publicly owned business, more than fifty percent of the stock is owned by one or more persons described in subdivision (a) of this subsection; and the management and daily business operations of the business are controlled by one or more persons described in subdivision (a) of this subsection.

Failure to submit the requested documentation within ten (10) business days of notice will disqualify the bidder from consideration of the preference.

P. BEST AND FINAL OFFER

If BAFOs are requested by the State and submitted by the bidder, they will be evaluated (using the stated BAFO criteria) and ranked by the Evaluation Committee. The State reserves the right to conduct more than one BAFO. The award will then be granted to the lowest responsible bidder. However, a bidder should provide its best offer in its original bid. Bidders should not expect that the State will request a BAFO.

Q. REFERENCE AND CREDIT CHECKS

The State reserves the right to conduct and consider reference and credit checks. The State reserves the right to use third parties to conduct reference and credit checks. By submitting a bid in response to this bid, the bidder grants to the State the right to contact or arrange a visit in person with any or all of the bidder's clients. Reference and credit checks may be grounds to reject a bid, withdraw an intent to award, or rescind the award of a contract.

R. AWARD

The State reserves the right to evaluate bids and award contracts in a manner utilizing criteria selected at the State's discretion and in the State's best interest. After evaluation of the bids, or at any point in the bid process, the State of Nebraska may take one (1) or more of the following actions:

1. Amend the bid;
2. Extend the time of or establish a new bid opening time;
3. Waive deviations or errors in the State's bid process and in bidder bids that are not material, do not compromise the bid process or a bidder's bid, and do not improve a bidder's competitive position;
4. Accept or reject a portion of or all of a bid;
5. Accept or reject all bids;
6. Withdraw the bid;
7. Elect to rebid the bid;
8. Award single lines or multiple lines to one (1) or more bidders; or,
9. Award one (1) or more all-inclusive contracts.

The State of Nebraska may consider, but is not limited to considering, one (1) or more of the following award criteria:

1. Price;
2. Location;
3. Quality;
4. Delivery time;
5. Bidder qualifications and capabilities; and,
6. State contract management requirements and/or costs.

The bid does not commit the State to award a contract. Once intent to award decision has been determined, it will be posted to the Internet at:

<https://das.nebraska.gov/materiel/bidopps.html>

Any protests must be filed by a bidder within ten (10) business days after the intent to award decision is posted to the Internet. Grievance and protest procedure is available on the Internet at:

<https://das.nebraska.gov/forms/index.html#mat>

S. DISCOUNTS

Prices quoted shall be inclusive of ALL trade discounts. Cash discount terms of less than thirty (30) days will not be considered as part of the bid. Cash discount periods will be computed from the date of receipt of a properly executed claim voucher or the date of completion of delivery of all items in a satisfactory condition, whichever is later.

T. PRICES

Prices quoted shall be net, **including transportation and delivery charges fully prepaid by the Vendor**, and FOB Destination as named in the ITB. **No additional charges will be allowed for packing, packages, or partial delivery costs.** When an arithmetic error has been made in the extended total the unit price will govern.

All prices, costs, and terms and conditions submitted in the bid shall remain fixed and valid commencing on the opening date of the bid and shall remain firm for the first one hundred twenty (120) days of the contract award.

Requests for an increase must be submitted in writing to SPB. SPB has a minimum of thirty (30) days to review and award any Price increase or decrease (after documentation is approved). Documentation will be required by the State to support the price increase.

The State reserves the right to deny any requested price increase.

No price increases are to be billed to the State prior to an Amendment to the Contract, which has been signed and completed by both the State and the awarded bidder, the Amendment is posted to the State Purchasing Bureau website and written notice has been given to both the State and the awarded bidder.

The State will be given full proportionate benefit of any decreases for the term of the contract.

U. SPECIFICATIONS

Any manufacturer's names, trade names, brand names, information and/or catalog numbers listed in a specification are for reference and not intended to limit competition but will be used as the standard by which equivalent material offered will be judged. The Materiel Administrator will be the sole judge of equivalency. The Bidder may offer any brands which meets or exceeds the specification. When a specific product is required, the bid will so state. Any item bid is to be the latest current model under standard production at the time of order. No used or refurbished equipment will be accepted, unless otherwise stated.

V. ALTERNATE/EQUIVALENT BIDS

Bidder may offer bids which are at variance from the express specifications of the solicitation. The State reserves the right to consider and accept such bids if, in the judgment of the Materiel Administrator, the bid will result in goods and/or services equivalent to or better than those which would be supplied in the original bid specifications. Bidder must indicate on the solicitation the manufacturer's name, number and shall submit with their bid, sketches, descriptive literature and/or complete specifications. Reference to literature submitted with a previous bid will not satisfy this provision. Bids which do not comply with these requirements are subject to rejection. In the absence of any stated deviation or exception, the bid will be accepted as in strict compliance with all terms, conditions and specification, and the Bidder shall be held liable, therefore.

W. "LUMP SUM" OR "ALL OR NONE" BIDS

The State reserves the right to purchase "item-by-item", by groups or as a total when the State may benefit by so doing. Bidders may submit a bid on an "all or none" or "lump sum" basis but should also submit a bid on an "item-by-item" basis. The term "all or none" means a conditional bid which requires the purchase of all items on which bids are offered and Bidder declines to accept award on individual items; a "lump sum" bid is one in which the Bidder offers a lower price than the sum of the individual bids if all items are purchased but agrees to deliver individual items at the prices quoted.

"LUMP SUM" OR "ALL OR NONE" BIDS SHOULD BE CONSPICUOUSLY MARKED ON THE FIRST PAGE OF THE ITB AND BID SHEET (IF APPLICABLE)

X. EMAIL SUBMISSIONS

SPB will not accept bids by email, electronic, voice, or telephone bids **except** for one-time purchases under \$50,000.00.

Y. BID TABULATIONS

Bid tabulations are available on the website at: <https://das.nebraska.gov/materiel/bidopps.html>

Z. REJECTION OF BIDS

The State reserves the right to reject any or all bids, wholly or in part, in the best interest of the State.

AA. RESIDENT BIDDER

Pursuant to Neb. Rev. Stat. §§ 73-101.01 through 73-101.02, a Resident Bidder shall be allowed a preference against a Non-resident Bidder from a state which gives or requires a preference to Bidders from that state. The preference shall be equal to the preference given or required by the state of the Nonresident Bidders. Where the lowest responsible bid from a resident Bidder is equal in all respects to one from a nonresident Bidder from a state which has no preference law, the resident Bidder shall be awarded the contract. The provision of this preference shall not apply to any contract for any project upon which federal funds would be withheld because of the provisions of this preference.

II. TERMS AND CONDITIONS

Bidders should complete Section II through VIII as part of their bid. Bidder is expected to read the Terms and Conditions and must initial either accept, reject, or reject and provide alternative language for each clause. The Bidder should also provide an explanation of why the Bidder rejected the clause or rejected the clause and provided alternate language using "Track Changes". Upon request an electronic copy of the bid with "Track Changes" must be submitted in an editable Word format. By signing the bid, Bidder is agreeing to be legally bound by all the accepted terms and conditions, and any proposed alternative terms and conditions submitted with the bid. The State reserves the right to negotiate rejected or proposed alternative language. If the State and Bidder fail to agree on the final Terms and Conditions, the State reserves the right to reject the bid. The State is soliciting bids in response to the bid. The State reserves the right to reject bids that attempt to substitute the Bidder's commercial contracts and/or documents for this bid.

The Bidder should submit with their bid any license, user agreement, service level agreement, or similar documents that the Bidder wants incorporated in the Contract. Upon notice of Intent to Award, the Bidder must submit a copy of these documents in an editable Word format. The State will not consider incorporation of any document not submitted with the Bidder's bid. These documents shall be subject to negotiation and will be incorporated as addendums if agreed to by the Parties.

If a conflict or ambiguity arises after the addendums have been negotiated and agreed to, the addendums shall be interpreted as follows:

1. If only one (1) Party's document has a particular clause, then that clause shall control;
2. If both Party's documents have a similar clause, but the clauses do not conflict, the clauses shall be read together;
3. If both Party's documents have a similar clause, but the clauses conflict, the State's clause shall control.

A. GENERAL

Accept (Initial)	Reject (Initial)	Reject & Provide Alternative Response (Initial)	NOTES/COMMENTS:
NW			

The contract resulting from this bid shall incorporate the following documents. These documents constitute the entirety of the contract:

1. ITB and Addenda;
2. Amendments to the bid;
3. Questions and Answers;
4. Bidder's bid response;
5. The executed Contract and any Addenda, if applicable, and properly submitted documents; and,
6. Amendments to the Contract

Unless otherwise specifically stated in a future contract amendment, in case of any conflict between the incorporated documents, the documents shall govern in the following order of preference with number one (1) receiving preference over all other documents and with each lower numbered document having preference over any higher numbered document: 1) Amendment to the executed Contract with the most recent dated amendment having the highest priority, 2) executed Contract and any attached Addenda, 3) Amendments to bid and any Questions and Answers, 4) the original bid document and any Addenda, and 5) the Bidder's submitted Bid. Any ambiguity or conflict in the contract discovered after its execution, not otherwise addressed herein, shall be resolved in accordance with the rules of contract interpretation as established in the State.

B. NOTIFICATION

Accept (Initial)	Reject (Initial)	Reject & Provide Alternative Response (Initial)	NOTES/COMMENTS:
NW			

Communication regarding the executed contract shall be given in writing and deemed to have been delivered via email to the specified Contract Contact information provided on the submitted ITB form with the submitted bid(s). The Vendor should send written notice to the SPB. The State will send notices to the authorized contact provided on the ITB form. Either party may change its address for notification purposes by giving notice of the change and setting forth the new address and an effective date.

C. PCO REPRESENTATIVE

The State reserves the right to appoint a PCO's Representative to manage [or assist the PCO in managing] the contract on behalf of the State. The PCO's Representative will be appointed in writing, and the appointment document will specify the extent of the PCO's Representative authority and responsibilities. If a PCO's Representative is appointed, the Bidder will be provided a copy of the appointment document and is expected to cooperate accordingly with the PCO's Representative. The PCO's Representative has no authority to bind the State to a contract, amendment, addendum, or other change or addition to the contract.

D. GOVERNING LAW (Statutory)

Notwithstanding any other provision of this contract, or any amendment or addendum(s) entered into contemporaneously or at a later time, the parties understand and agree that, (1) the State of Nebraska is a sovereign state and its authority to contract is therefore subject to limitation by the State's Constitution, statutes, common law, and regulation; (2) this contract will be interpreted and enforced under the laws of the State of Nebraska; (3) any action to enforce the provisions of this contract must be brought in the State of Nebraska per state law; (4) the person signing this contract on behalf of the State of Nebraska does not have the authority to waive the State's sovereign immunity, statutes, common law, or regulations; (5) the indemnity, limitation of liability, remedy, and other similar provisions of the final contract, if any, are entered into subject to the State's Constitution, statutes, common law, regulations, and sovereign immunity; and, (6) all terms and conditions of the final contract, including but not limited to the clauses concerning third-party use, licenses, warranties, limitations of liability, governing law and venue, usage verification, indemnity, liability, remedy or other similar provisions of the final contract are entered into specifically subject to the State's Constitution, statutes, common law, regulations, and sovereign immunity. The Parties must comply with all applicable local, state, and federal laws, ordinances, rules, orders, and regulations.

E. AMENDMENT

This Contract may be amended in writing, within scope, upon the agreement of both parties.

F. SUBSTITUTIONS

Accept (Initial)	Reject (Initial)	Reject & Provide Alternative Response (Initial)	NOTES/COMMENTS:
NW			

In the event any product is discontinued or replaced upon mutual consent during the contract period or prior to delivery, the State reserves the right to amend the contract or purchase order to include the alternate product at the same price.

If the Vendor requests to substitute any contracted item and the substitute meets or exceeds the original specifications, the State may accept or reject the substitution.

If the Vendor requests to substitute any contracted item, which meets or exceeds the original specifications, and the cost of the substitute is higher, the State may accept or reject the substitution and price change.

If the State and the Vendor do not agree to the requested substitution and price change, the Contract may be terminated immediately by the State. In the event any product is discontinued or replaced upon mutual consent and prior to delivery during the Contract Period the State reserves the right to amend the contract or purchase order to include the alternate product.

*****Bidder will not substitute any item that has been awarded without prior written approval of SPB*****

G. VENDOR PERFORMANCE REPORT(S)

Accept (Initial)	Reject (Initial)	Reject & Provide Alternative Response (Initial)	NOTES/COMMENTS:
NW			

The State may document any instance(s) of products or services delivered or performed which exceed or fail to meet the terms of the purchase order, contract, and/or bid specifications. The State Purchasing Bureau may contact the Bidder regarding any such report. Bidder performance report(s) will become a part of the permanent record of the Bidder.

H. NOTICE OF POTENTIAL BIDDER BREACH

Accept (Initial)	Reject (Initial)	Reject & Provide Alternative Response (Initial)	NOTES/COMMENTS:
NW			

If Bidder breaches the contract or anticipates breaching the contract, the Bidder shall immediately give written notice to the State. The notice shall explain the breach or potential breach, a proposed cure, and may include a request for a waiver of the breach if so desired. The State may, in its discretion, temporarily or permanently waive the breach. By granting a waiver, the State does not forfeit any rights or remedies to which the State is entitled by law or equity, or pursuant to the provisions of the contract. Failure to give immediate notice, however, may be grounds for denial of any request for a waiver of a breach.

I. BREACH

Accept (Initial)	Reject (Initial)	Reject & Provide Alternative Response (Initial)	NOTES/COMMENTS:
NW			

Either Party may terminate the contract, in whole or in part, if the other Party breaches its duty to perform its obligations under the contract in a timely and proper manner. Termination requires written notice of default and a thirty (30) calendar day (or longer at the non-breaching Party's discretion considering the gravity and nature of the default) cure period. Said notice shall be delivered by Certified Mail, Return Receipt Requested, or in person with proof of delivery. Allowing time to cure a failure or breach of contract does not waive the right to immediately terminate the contract for the same or different contract breach which may occur at a different time.

In case of breach by the Bidder, the State may, without unreasonable delay, make a good faith effort to make a reasonable purchase or contract to purchased goods in substitution of those due from the bidder. The State may recover from the Bidder as damages the difference between the costs of covering the breach. Notwithstanding any clause to the contrary, the State may also recover the contract price together with any incidental or consequential damages defined in UCC Section 2-715, but less expenses saved in consequence of Bidder's breach. OR In case of default of the Bidder, the State may contract the service from other sources and hold the Bidder responsible for any excess cost occasioned thereby.

The State's failure to make payment shall not be a breach, and the Bidder shall retain all available statutory remedies. (See Indemnity - Self-Insurance and Payment)

J. NON-WAIVER OF BREACH

Accept (Initial)	Reject (Initial)	Reject & Provide Alternative Response (Initial)	NOTES/COMMENTS:
NW			

The acceptance of late performance with or without objection or reservation by a Party shall not waive any rights of the Party nor constitute a waiver of the requirement of timely performance of any obligations remaining to be performed.

K. SEVERABILITY

Accept (Initial)	Reject (Initial)	Reject & Provide Alternative Response (Initial)	NOTES/COMMENTS:
NW			

If any term or condition of the contract is declared by a court of competent jurisdiction to be illegal or in conflict with any law, the validity of the remaining terms and conditions shall not be affected, and the rights and obligations of the parties shall be construed and enforced as if the contract did not contain the provision held to be invalid or illegal.

L. INDEMNIFICATION

Accept (Initial)	Reject (Initial)	Reject & Provide Alternative Response (Initial)	NOTES/COMMENTS:
NW			

1. GENERAL

The Bidder agrees to defend, indemnify, and hold harmless the State and its employees, volunteers, agents, and its elected and appointed officials ("the indemnified parties") from and against any and all claims, liens, demands, damages, liability, actions, causes of action, losses, judgments, costs, and expenses of every nature, including investigation costs and expenses, settlement costs, and attorney fees and expenses ("the claims"), sustained or asserted against the State for personal injury, death, or property loss or damage, arising out of, resulting from, or attributable to the willful misconduct, negligence, error, or omission of the Bidder, its employees, Subcontractors, consultants, representatives, and agents, resulting from this contract, except to the extent such Bidder liability is attenuated by any action of the State which directly and proximately contributed to the claims.

2. SELF-INSURANCE (Statutory)

The State is self-insured for any loss and purchases excess insurance coverage pursuant to Neb. Rev. Stat. § 81-8,239.01 (Reissue 2008). If there is a presumed loss under the provisions of this contract, Bidder may file a claim with the Office of Risk Management pursuant to Neb. Rev. Stat. §§ 81-8,829 through 81-8,306 for review by the State Claims Board. The State retains all rights and immunities under the State Miscellaneous (Section 81-8,294), Tort (Section 81-8,209), and Contract Claim Acts (Section 81-8,302), as outlined in Neb. Rev. Stat. § 81-8,209 et seq. and under any other provisions of law and accepts liability under this contract to the extent provided by law.

M. ATTORNEY'S FEES

Accept (Initial)	Reject (Initial)	Reject & provide Alternative Response (Initial)	NOTES/COMMENTS:
NW			

In the event of any litigation, appeal, or other legal action to enforce any provision of the contract, the Parties agree to pay all expenses of such action, as permitted by law and if ordered by the court, including attorney's fees and costs, if the other party prevails.

N. ASSIGNMENT, SALE, OR MERGER

Accept (Initial)	Reject (Initial)	Reject & Provide Alternative Response (Initial)	NOTES/COMMENTS:
NW			

Either party may assign the contract upon mutual written agreement of the other party. Such agreement shall not be unreasonably withheld.

The Bidder retains the right to enter into a sale, merger, acquisition, internal reorganization, or similar transaction involving Bidder's business. Bidder agrees to cooperate with the State in executing amendments to the contract to allow for the transaction. If a third party or entity is involved in the transaction, the Bidder will remain responsible for performance of the contract until such time as the person or entity involved in the transaction agrees in writing to be contractually bound by this contract and perform all obligations of the contract.

O. CONTRACTING WITH OTHER POLITICAL SUB-DIVISIONS OF THE STATE OR ANOTHER STATE

Accept (Initial)	Reject (Initial)	Reject & Provide Alternative Response (Initial)	NOTES/COMMENTS:
NW			

The Bidder may, but shall not be required to, allow agencies, as defined in Neb. Rev. Stat. § 81-145, to use this contract. The terms and conditions, including price, of the contract may not be amended. The State shall not be contractually obligated or liable for any contract entered into pursuant to this clause.

The Bidder may, but shall not be required to, allow other states, agencies or divisions of other states, or political subdivisions of other states to use this contract. The terms and conditions, including price, of this contract shall apply to any such contract, but may be amended upon mutual consent of the Parties. The State of Nebraska shall not be contractually or otherwise obligated or liable under any contract entered into pursuant to this clause. The State shall be notified if a contract is executed based upon this contract.

P. FORCE MAJEURE

Accept (Initial)	Reject (Initial)	Reject & Provide Alternative Response (Initial)	NOTES/COMMENTS:
NW			

Neither party shall be liable for any costs or damages, or for default resulting from its inability to perform any of its obligations under the contract due to a natural or man-made event outside the control and not the fault of the affected party ("Force Majeure Event"). The Party so affected shall immediately make a written request for relief to the other party and shall have the burden of proof to justify the request. The other Party may grant the relief requested; relief may not be unreasonably withheld. Labor disputes with the impacted party's own employees will not be considered a Force Majeure Event.

Q. CONFIDENTIALITY

Accept (Initial)	Reject (Initial)	Reject & Provide Alternative Response (Initial)	NOTES/COMMENTS:
NW			

All materials and information provided by the Parties or acquired by a Party on behalf of the other Party shall be regarded as confidential information. All materials and information provided or acquired shall be handled in accordance with federal and state law, and ethical standards. Should said confidentiality be breached by a Party, the Party shall notify the other Party immediately of said breach and take immediate corrective action.

It is incumbent upon the Parties to inform their officers and employees of the penalties for improper disclosure imposed by the Privacy Act of 1974, 5 U.S.C. 552a. Specifically, 5 U.S.C. 552a (i)(1), which is made applicable by 5 U.S.C. 552a (m)(1), provides that any officer or employee, who by virtue of his/her employment or official position has possession of or access to agency records which contain individually identifiable information, the disclosure of which is prohibited by the Privacy Act or regulations established thereunder, and who knowing that disclosure of the specific material is prohibited, willfully discloses the material in any manner to any person or agency not entitled to receive it, shall be guilty of a misdemeanor and fined not more than \$5,000.00.

R. EARLY TERMINATION

Accept (Initial)	Reject (Initial)	Reject & Provide Alternative Response (Initial)	NOTES/COMMENTS:
NW			

The contract may be terminated as follows:

1. The State and the Bidder, by mutual written agreement, may terminate the contract at any time.
2. The State, at its sole discretion, may terminate the contract for any reason upon thirty (30) calendar day's written notice to the Bidder. Such termination shall not relieve the Bidder of warranty or other service obligations incurred under the terms of the contract. In the event of termination, the Bidder shall be entitled to payment, determined on a pro rata basis, for products or services satisfactorily performed or provided.
3. The State may terminate the contract immediately for the following reasons:
 - a. if directed to do so by statute;
 - b. Bidder has made an assignment for the benefit of creditors, has admitted in writing its inability to pay debts as they mature, or has ceased operating in the normal course of business;
 - c. a trustee or receiver of the Bidder or of any substantial part of the Bidder's assets has been appointed by a court;
 - d. fraud, misappropriation, embezzlement, malfeasance, misfeasance, or illegal conduct pertaining to performance under the contract by its Bidder, its employees, officers, directors, or shareholders;
 - e. an involuntary proceeding has been commenced by any party against the Bidder under any one of the chapters of Title 11 of the United States Code and (i) the proceeding has been pending for at least sixty (60) calendar days; or (ii) the Bidder has consented, either expressly or by operation of law, to the entry of an order for relief; or (iii) the Bidder has been decreed or adjudged a debtor;
 - f. a voluntary petition has been filed by the Bidder under any of the chapters of Title 11 of the United States Code;

- g.** Bidder intentionally discloses confidential information;
- h.** Bidder has or announces it will discontinue support of the deliverable; and,
- i.** In the event funding is no longer available.

III. BIDDER DUTIES

A. INDEPENDENT BIDDER / OBLIGATIONS

Accept (Initial)	Reject (Initial)	Reject & provide Alternative Response (Initial)	NOTES/COMMENTS:
AW			

It is agreed that the Bidder is an independent bidder and that nothing contained herein is intended or should be construed as creating or establishing a relationship of employment, agency, or a partnership.

The Bidder is solely responsible for fulfilling the contract. The Bidder or the Bidder's representative shall be the sole point of contact regarding all contractual matters.

The Bidder shall secure, at its own expense, all personnel required to perform the services under the contract. The personnel the Bidder uses to fulfill the contract shall have no contractual or other legal relationship with the State; they shall not be considered employees of the State and shall not be entitled to any compensation, rights, or benefits from the State, including but not limited to, tenure rights, medical and hospital care, sick and vacation leave, severance pay, or retirement benefits.

By-name personnel commitments made in the Bidder's bid shall not be changed without the prior written approval of the State. Replacement of these personnel, if approved by the State, shall be with personnel of equal or greater ability and qualifications.

The Bidder warrants that all persons assigned to the project shall be employees of the Bidder or a Subcontractor and shall be fully qualified to perform the work required herein. Personnel employed by the Bidder or a subcontractor to fulfill the terms of the contract shall remain under the sole direction and control of the Bidder or the subcontractor respectively.

With respect to its employees, the Bidder agrees to be solely responsible for the following:

1. Any and all pay, benefits, and employment taxes and/or other payroll withholding;
2. Any and all vehicles used by the Bidder's employees, including all insurance required by state law;
3. Damages incurred by Bidder's employees within the scope of their duties under the contract;
4. Maintaining Workers' Compensation and health insurance that complies with state and federal law and submitting any reports on such insurance to the extent required by governing law;
5. Determining the hours to be worked and the duties to be performed by the Bidder's employees; and,
6. All claims on behalf of any person arising out of employment or alleged employment (including without limit claims of discrimination alleged against the Bidder, its officers, agents, or subcontractors or subcontractor's employees).

If the Bidder intends to utilize any subcontractor, the Subcontractor's level of effort, tasks, and time allocation must be clearly defined in the Bidder's bid. The Bidder shall agree that it will not utilize any Subcontractors not specifically included in its bid in the performance of the contract without the prior written authorization of the State.

The State reserves the right to require the Bidder to reassign or remove from the project any Bidder or Subcontractor employee.

Bidder shall insure that the terms and conditions contained in any contract with a sub-contractor does not conflict with the terms and conditions of this contract.

The Bidder shall include a similar provision, for the protection of the State, in the contract with any Subcontractor engaged to perform work on this contract.

B. EMPLOYEE WORK ELIGIBILITY STATUS

The Bidder is required and hereby agrees to use a federal immigration verification system to determine the work eligibility status of employees physically performing work within the State. A federal immigration verification system means the electronic verification of the work authorization program authorized by the Illegal Immigration Reform and Immigrant Responsibility Act of 1996, 8 U.S.C. 1324a, known as the E-Verify Program, or an equivalent federal program designated by the United States Department of Homeland Security or other federal agency authorized to verify the work eligibility status of an employee.

If the Bidder is an individual or sole proprietorship, the following applies:

1. The Bidder must complete the United States Citizenship Attestation Form, available on the DAS website at <http://das.nebraska.gov/materiel/purchasing.html>

The completed United States Attestation Form should be submitted with the bid response.

2. If the Bidder indicates on such attestation form that he or she is a qualified alien, the Bidder agrees to provide the U.S. Citizenship and Immigration Services documentation required to verify the Bidder's lawful presence in the United States using the Systematic Alien Verification for Entitlements (SAVE) Program.

3. The Bidder understands and agrees that lawful presence in the United States is required, and the Bidder may be disqualified, or the contract terminated if such lawful presence cannot be verified as required by Neb. Rev. Stat. § 4-108.

C. COMPLIANCE WITH CIVIL RIGHTS LAWS AND EQUAL OPPORTUNITY EMPLOYMENT / NONDISCRIMINATION (Statutory)

The Bidder shall comply with all applicable local, state, and federal statutes and regulations regarding civil rights laws and equal opportunity employment. The Nebraska Fair Employment Practice Act prohibits Bidders of the State, and their Subcontractors, from discriminating against any employee or applicant for employment, with respect to hire, tenure, terms, conditions, compensation, or privileges of employment because of race, color, religion, sex, disability, marital status, or national origin (Neb. Rev. Stat. §§ 48-1101 through 48-1125). The Bidder guarantees compliance with the Nebraska Fair Employment Practice Act, and breach of this provision shall be regarded as a material breach of contract. The Bidder shall insert a similar provision in all Subcontracts for goods or services to be covered by any contract resulting from this bid.

D. COOPERATION WITH OTHER BIDDERS

Accept (Initial)	Reject (Initial)	Reject & Provide Alternative Response (Initial)	NOTES/COMMENTS:
NW			

Bidder may be required to work with or in close proximity to other bidders or individuals that may be working on the same or different projects. The Bidder shall agree to cooperate with such other bidders or individuals and shall not commit or permit any act which may interfere with the performance of work by any other bidder or individual. Bidder is not required to compromise Bidder's intellectual property or proprietary information unless expressly required to do so by this contract.

E. COST CLARIFICATION

The State reserves the right to review all aspects of cost for reasonableness and to request clarification of any bid where the cost component shows significant and unsupported deviation from industry standards or in areas where detailed pricing is required.

F. PERMITS, REGULATIONS, LAWS

Accept (Initial)	Reject (Initial)	Reject & Provide Alternative Response (Initial)	NOTES/COMMENTS:
NW			

The contract price shall include the cost of all royalties, licenses, permits, and approvals, whether arising from patents, trademarks, copyrights or otherwise, that are in any way involved in the contract. The Bidder shall obtain and pay for all royalties, licenses, and permits, and approvals necessary for the performance of the contract. The Bidder must guarantee that it has the full legal right to the materials, supplies, equipment, software, and other items used to execute this contract.

G. NOTICE OF POTENTIAL BIDDER BREACH

Accept (Initial)	Reject (Initial)	Reject & Provide Alternative Response (Initial)	NOTES/COMMENTS:
NW			

If Bidder breaches the contract or anticipates breaching the contract the Bidder shall immediately give written notice to the State. The notice shall explain the breach or potential breach and may include a request for a waiver of the breach if so desired. The State may, at its discretion, temporarily or permanently waive the breach. By granting a temporary waiver, the State does not forfeit any rights or remedies to which the State is entitled by law or equity, or pursuant to the provisions of the contract. Failure to give immediate notice, however, may be grounds for denial of any request for a waiver of a breach.

H. ANTITRUST

Accept (Initial)	Reject (Initial)	Reject & Provide Alternative Response (Initial)	NOTES/COMMENTS:
NW			

NW			
----	--	--	--

The Bidder hereby assigns to the State any and all claims for overcharges as to goods and/or services provided in connection with this contract resulting from antitrust violations which arise under antitrust laws of the United States and the antitrust laws of the State.

I. CONFLICT OF INTEREST

Accept (Initial)	Reject (Initial)	Reject & Provide Alternative Response (Initial)	NOTES/COMMENTS:
NW			

By submitting a bid, bidder certifies that no relationship exists between the bidder and any person or entity which either is, or gives the appearance of, a conflict of interest related to this Request for Bid or project.

Bidder further certifies that bidder will not employ any individual known by bidder to have a conflict of interest nor shall bidder take any action or acquire any interest, either directly or indirectly, which will conflict in any manner or degree with the performance of its contractual obligations hereunder or which creates an actual or appearance of conflict of interest.

If there is an actual or perceived conflict of interest, bidder shall provide with its bid a full disclosure of the facts describing such actual or perceived conflict of interest and a proposed mitigation plan for consideration. The State will then consider such disclosure and proposed mitigation plan and either approve or reject as part of the overall bid evaluation.

J. ADVERTISING

Accept (Initial)	Reject (Initial)	Reject & Provide Alternative Response (Initial)	NOTES/COMMENTS:
NW			

The Bidder agrees not to refer to the contract award in advertising in such a manner as to state or imply that the company or its goods and services are endorsed or preferred by the State. Any publicity releases pertaining to the project shall not be issued without prior written approval from the State.

K. NEBRASKA TECHNOLOGY ACCESS STANDARDS (Statutory)

Bidder shall review the Nebraska Technology Access Standards, found at <http://nitc.nebraska.gov/standards/2-201.html> and ensure that products and/or goods provided under the contract are in compliance or will comply with the applicable standards to the greatest degree possible. In the event such standards change during the Bidder's performance, the State may create an amendment to the contract to request the contract comply with the changed standard at a cost mutually acceptable to the parties.

L. DISASTER RECOVERY/BACK UP PLAN

Accept (Initial)	Reject (Initial)	Reject & Provide Alternative Response (Initial)	NOTES/COMMENTS:
NW			

The Bidder shall have a disaster recovery and back-up plan, of which a copy should be provided upon request to the State, which includes, but is not limited to equipment, personnel, facilities, and transportation, to continue delivery of goods and services as specified under the specifications in the contract in the event of a disaster.

M. DRUG POLICY

Accept (Initial)	Reject (Initial)	Reject & Provide Alternative Response (Initial)	NOTES/COMMENTS:
NW			

Bidder certifies it maintains a drug free workplace environment to ensure worker safety and workplace integrity. Bidder agrees to provide a copy of its drug free workplace policy at any time upon request by the State.

N. WARRANTY

Accept (Initial)	Reject (Initial)	Reject & Provide Alternative Response (Initial)	NOTES/COMMENTS:
NW			

Despite any clause to the contrary, the Bidder represents and warrants that its services hereunder shall be performed by competent personnel and shall be of professional quality consistent with generally accepted industry standards for the performance of such services and shall comply in all respects with the requirements of this Contract. For any breach of this warranty, the Bidder shall, for a period of ninety (90) days from performance of the service, perform the services again, at no cost to Customer, or if Bidder is unable to perform the services as warranted, Bidder shall reimburse Customer the fees paid to Bidder for the unsatisfactory services. The rights and remedies of the parties under this warranty are in addition to any other rights and remedies of the parties provided by law or equity, including, without limitation actual damages, and, as applicable and awarded under the law, to a prevailing party, reasonable attorneys' fees, and costs.

IV. PAYMENT

A. PROHIBITION AGAINST ADVANCE PAYMENT (Statutory)

Neb. Rev. Stat. § 81-2403 states, “[n]o goods or services shall be deemed to be received by an agency until all such goods or services are completely delivered and finally accepted by the agency.”

B. TAXES (Statutory)

The State is not required to pay taxes and assumes no such liability as a result of this bid. The Bidder may request a copy of the Nebraska Department of Revenue, Nebraska Resale or Exempt Sale Certificate for Sales Tax Exemption, Form 13 for their records. Any property tax payable on the Bidder's equipment which may be installed in a state-owned facility is the responsibility of the Bidder.

C. INVOICES

Invoices for payments must be submitted by the Bidder to the agency requesting the services with sufficient detail to support payment. The terms and conditions included in the Bidder's invoice shall be deemed to be solely for the convenience of the parties. No terms or conditions of any such invoice shall be binding upon the State, and no action by the State, including without limitation the payment of any such invoice in whole or in part, shall be construed as binding or estopping the State with respect to any such term or condition, unless the invoice term or condition has been previously agreed to by the State as an amendment to the contract.

D. INSPECTION AND APPROVAL

Accept (Initial)	Reject (Initial)	Reject & Provide Alternative Response (Initial)	NOTES/COMMENTS:
NW			

Final inspection and approval of all work required under the contract shall be performed by the designated State officials.

The State and/or its authorized representatives shall have the right to enter any premises where the Bidder or Subcontractor duties under the contract are being performed, and to inspect, monitor or otherwise evaluate the work being performed. All inspections and evaluations shall be at reasonable times and in a manner that will not unreasonably delay work.

E. PAYMENT (Statutory)

Payment will be made by the responsible agency in compliance with the State of Nebraska Prompt Payment Act (See Neb. Rev. Stat. § 81-2403). The State may require the Bidder to accept payment by electronic means such as ACH deposit. In no event shall the State be responsible or liable to pay for any goods and services provided by the Bidder prior to the Effective Date of the contract, and the Bidder hereby waives any claim or cause of action for any such services.

F. LATE PAYMENT (Statutory)

The Bidder may charge the responsible agency interest for late payment in compliance with the State of Nebraska Prompt Payment Act (See Neb. Rev. Stat. §§ 81-2401 through 81-2408).

G. SUBJECT TO FUNDING / FUNDING OUT CLAUSE FOR LOSS OF APPROPRIATIONS (Statutory)

The State's obligation to pay amounts due on the Contract for a fiscal year following the current fiscal year is contingent upon legislative appropriation of funds. Should said funds not be appropriated, the State may terminate the contract with respect to those payments for the fiscal year(s) for which such funds are not appropriated. The State will give the Bidder written notice thirty (30) calendar days prior to the effective date of termination. All obligations of the State to make payments after the termination date will cease. The Bidder shall be entitled to receive just and equitable compensation for any authorized work which has been satisfactorily completed as of the termination date. In no event shall the Bidder be paid for a loss of anticipated profit.

H. RIGHT TO AUDIT (First Paragraph is Statutory)

Accept (Initial)	Reject (Initial)	Reject & Provide Alternative Response (Initial)	NOTES/COMMENTS:
NW			

The State shall have the right to audit the Bidder's performance of this contract upon a thirty (30) day written notice. Bidder shall utilize generally accepted accounting principles, and shall maintain the accounting records, and other records and information relevant to the contract (Information) to enable the State to audit the contract. (Neb. Rev. Stat. § 84-304 et seq.) The State may audit, and the Bidder shall maintain the information during the term of the contract and for a period of five (5) years after the completion of this contract or until all issues or litigation are resolved, whichever is later. The Bidder shall make the Information available to the State at Bidder's place of business or a location acceptable to both Parties during normal business hours. If this is not practical or the Bidder so elects, the Bidder may provide electronic or paper copies of the Information. The State reserves

the right to examine, make copies of, and take notes on any Information relevant to this contract, regardless of the form or the Information, how it is stored, or who possesses the Information. In no circumstances will bidder be required to create or maintain documents not kept in the ordinary course of bidder's business operations, nor will bidder be required to disclose any information, including but not limited to product cost data, which is confidential or proprietary to bidder.

The Parties shall pay their own costs of the audit unless the audit finds a previously undisclosed overpayment by the State. If a previously undisclosed overpayment exceeds two and one-half percent (2.5%) of the total contract billings, or if fraud, material misrepresentations, or non-performance is discovered on the part of the Bidder, the Bidder shall reimburse the State for the total costs of the audit. Overpayments and audit costs owed to the State shall be paid within ninety (90) days of written notice of the claim. The Bidder agrees to correct any material weaknesses or condition found as a result of the audit.

V. SCOPE OF WORK

A. SCOPE

It is the intent of this bid invitation to establish a contract to supply **Articulated AWD Loader with Minimum 2.7 CY Bucket** per the attached specifications from date of award for a period of One (1) year with the option to renew for an additional four (4) One (1) year periods when mutually agreeable to the bidder and the State. The State reserves the right to extend the period of this contract beyond the end date when mutually agreeable to the bidder and the State.

All items proposed shall be of the latest manufacture in production as of the date of the bid and be of proven performance and under standard design complete as regularly advertised and marketed. All necessary materials for satisfactory performance of the supplies shall be incorporated into the **Articulated AWD Loader with Minimum 2.7 CY Bucket** whether or not they may be specifically mentioned below.

Complete specifications, manufacturer's current descriptive literature and/or advertising data sheets with cuts or photographs must be included with the bid for the IDENTICAL items proposed. Any information necessary to show compliance with these specifications not given on the manufacturer's descriptive literature and/or advertising data sheets must be supplied in writing on or attached to the bid document. If manufacturer's information necessary to show compliance with these specifications is not attached to the bid document, the Bidder may be required to submit requested information within three (3) business days of a written request. Failure to submit requested descriptive literature or advertising data sheets may be grounds to reject the bid.

VI. TECHNICAL SPECIFICATIONS

A. BIDDER INSTRUCTIONS

Bidder must respond to each of the following statements. Specifications listed are minimum conditions that must be met in order for a Bidder to qualify for the award.

“YES” response means the Bidder guarantees they can meet this condition.

“NO” response means the Bidder cannot meet this condition and will not be considered.

“NO & PROVIDE ALTERNATIVE” responses should be used only with a narrative response in the “NOTES/COMMENTS” section explaining in detail any deviation from the Bidder’s ability to meet the condition, and an explanation of how this would be determined to be an acceptable alternative to meeting the condition. Alternatives must be detailed in such a way that allows such deviations to be fully evaluated. The State shall determine at its sole discretion whether or not the Bidder’s alternative is an acceptable alternative.

B. NON-COMPLIANCE STATEMENT

YES	NO	NO & PROVIDE ALTERNATIVE	
X			1. Read these specifications carefully.
X			2. Any and all exceptions to these specifications must be written on or attached to solicitation response.
X			3. Any noncompliance may void your bid. Non-compliance to any single specification can void your bid.
X			4. It is the responsibility of Bidders to obtain information and clarifications as provided below.
X			5. The State is not responsible for any erroneous or incomplete understandings or wrongful interpretations of this solicitation by any Bidder.
NOTES/COMMENTS:			

C. ENGINE

YES	NO	NO & PROVIDE ALTERNATIVE	
X			1. Diesel engine shall be a minimum of 6.6 Liters.
X			2. Engine shall have a minimum one hundred sixty-six (166) net horsepower developed at SAE J1349 or ISO 9249 under standard conditions with all accessories.
X			3. Cold starting aid of: Glow plugs; equivalent pre-heater; or ether injection of Turner LP535-1 or equivalent with cartridge required. Specify which item in the “NOTES/COMMENTS” section below.
X			4. Manufacturer’s recommended muffler, alternator, and starter.
X			5. Full flow, throw away type oil filter(s) required.
X			6. Turbo II or Centri brand pre-cleaner or equivalent OEM supplied rotary ejection style pre-cleaner required. Dual element air filtration is preferred.
X			7. Heavy-duty radiator guard and crankcase guard is desired.
X			8. Engine housing side panels or tilt hood required.
X			9. Manufacturer’s recommended type antifreeze protection to no less than thirty-four (34) degrees below zero Fahrenheit required.
X			10. A one hundred twenty (120) volt AC block heater with a sturdily mounted, male receptacle with cover that is conveniently located will be furnished in all water-cooled units.
X			11. Counter-balanced rain cap for exhaust preferred. Exhaust elbow is acceptable.

X			12. Specify fuel tank capacity in the "NOTES/COMMENTS" section below.
X			13. Please specify the following information:
X			a. Engine Brand: John Deere
X			b. Engine Model: E6068 H
X			c. Flywheel Horsepower: 166
X			d. Governed RPM: 1900
NOTES/COMMENTS: C. 3. Pre Heat. C. 12. Fuel Tank 76.6 gallons			

D. DRIVE

YES	NO	NO & PROVIDE ALTERNATIVE	
X			1. Torque converter/power shift with minimum four (4) speed forward and three (3) reverse transmission. Hydrostatic transmission is also acceptable.
X			2. Inboard or outboard four (4) wheel planetary final reduction.
X			3. Limited slip in front and/or rear differential required. Either front or rear differential lock-up will be acceptable. Specify what will be bid in the "NOTES/COMMENTS" section below.
X			4. Minimum forward travel speed will be approximately twenty (20) MPH.
NOTES/COMMENTS: D. 3. Locking Front Differential.			

E. TIRES AND WHEELS

YES	NO	NO & PROVIDE ALTERNATIVE	
X			1. Four (4) 20.5R25, Michelin XTLA or Equivalent: Specify brand in the "NOTES/COMMENTS" section below.
NOTES/COMMENTS: E. 1. Maxam 20.5R25 L3 STAR RADIAL TIRES W/3 PC RIMS			

F. BRAKES

YES	NO	NO & PROVIDE ALTERNATIVE	
X			1. Brakes on all four (4) wheels.
X			2. Brakes shall be boosted, full hydraulic type or air brakes. Specify type of brakes bid in the "NOTES/COMMENTS" section below.
X	X	Hydraulic	3. Air dryer or equivalent moisture remover required with air brakes.
X			4. Transmission drive or internal wet disk service brakes acceptable.
X			5. Parking brake required.

NOTES/COMMENTS: F. Z. Hydraulic sealed multi disc.

G. STEERING

YES	NO	NO & PROVIDE ALTERNATIVE	
X			1. Articulated frame at wheelbase center point.
X			2. Turn to right and left of at least forty (40) degrees.
X			3. To be hydraulically assisted.
NOTES/COMMENTS:			

H. LOADER

YES	NO	NO & PROVIDE ALTERNATIVE	
X			1. Static full turn tipping load must be a minimum of 19,000 pounds.
X			2. Joystick control.
X			3. General purpose loader bucket to be minimum 2.7 CY struck SAE rated.
X			4. Bucket shall be minimum ninety-six inches (96") wide but not less than the overall width of the machine.
X			5. Dump clearance at full lift with bucket at forty-five (45) degrees discharge shall be at least nine feet (9'), three inches (3").
	X	24,067	6. Minimum 25,000-pound breakout force.
X			7. Digging depth of at least 2.9 inches below grade with bucket bottom approaching position parallel to grade.
X			8. Bucket level indicator or automatic pre-set to dig position and adjustable automatic lift kick out required. Bucket shall have a bolt-on cutting edge.
X			9. Z-bar linkage or parallel Lift Linkage will be acceptable.
X			10. Loader shall be equipped with a suspension system for the loader boom cylinders. Ride Control/Suspension System to include any accumulators, valves, hydraulic lines and/or electrical circuits as required by the manufacturer.
NOTES/COMMENTS:			

I. CAB

YES	NO	NO & PROVIDE ALTERNATIVE	
X			1. The ROPS cab shall be of steel construction:
X			a. Cab shall be fully and tightly enclosed with sound suppression.
X			b. Tinted safety glass windshield, windows and door(s) required.
X			2. Cab to be equipped with mounting ladder:
X			a. Electric windshield wipers with washers both front and rear.

X			b.	Inside rear-view mirror(s) and floor mat required.
X			c.	Standard AM/FM radio Installed.
X			d.	Defroster fan and heater of adequate capacity for Nebraska required.
X			e.	Unit shall have manufacturer's factory installed air conditioning.
X			f.	Unit to have rearview camera installed.
X			g.	Loader must be able to be operated with door(s) secured open.
X			3.	Padded adjustable, cloth covered suspension seat with seat belt shall be provided.
NOTES/COMMENTS:				

J. INSTRUMENTS

YES	NO	NO & PROVIDE ALTERNATIVE	
X			1. The following gauges or digital displays are required:
	X	Hydraulic	a. Air pressure gauge if air brakes.
X			b. Torque converter or transmission oil temperature gauge.
X			c. Fuel gauge or indicator.
X			d. Oil pressure gauge.
X			e. Engine temperature gauge.
X			f. Voltmeter, ammeter, or warning light for the twelve (12) or twenty-four (24) volt system.
X			2. Audible and visible alarm system for high engine temperature, low oil pressure and high transmission oil temperature.
X			3. An electronic, back-up alarm meeting OSHA requirements to be provided.
NOTES/COMMENTS:			

K. HYDRAULIC SYSTEM

YES	NO	NO & PROVIDE ALTERNATIVE	
X			1. Constantly driven, gear, piston or vane type pump required.
X			2. Replaceable system filters and pressure relief valve required.
	X	3,650 PSI	3. System operation pressure shall be a maximum of 3,800 PSI.
X			4. Third Valve with all controls, Lines, Fittings, and couplers to front of loader boom for attachments.
NOTES/COMMENTS:			

L. COUNTERWEIGHTS

YES	NO	NO & PROVIDE ALTERNATIVE	
X			1. Standard equipment rear counterweights are required.
NOTES/COMMENTS:			

M. GENERAL

YES	NO	NO & PROVIDE ALTERNATIVE	
X			1. The overall length of the loader will not be greater than twenty-five feet (25'), ten inches (10"), with loader bucket level on the ground.
	X	28,646 lbs	2. The operation weight of loader with minimum 2.7 CY bucket, ROPS cab and without optional accessories or calcium chloride in tires shall be a minimum of 29,200 pounds. Specify loader weight in pounds in the "NOTES/COMMENTS" section below.
X			3. Four (4) LED headlights (two (2) at top of cab near corners and two (2) at bottom of cab near each side).
X			4. One (1) rear working LED light.
X			5. Combination LED stop/taillight and horn.
X			6. Drawbar hitch with pin.
X			7. Turn signal and hazard flashing LED lights for front and rear.
X			8. Manufacturer's front and rear fenders required.
X			9. A slow-moving vehicle emblem shall be mounted on the rear of loader and displayed as required per Nebraska Statutes.
X			a. Emblem shall be mounted so as not to restrict airflow for cooling purposes.
NOTES/COMMENTS: m2. 28,646 lbs with 2.75CY Bucket.			

N. NOISE LEVEL

YES	NO	NO & PROVIDE ALTERNATIVE	
X			1. Bidder should supply with bid the following decibel level per SAE Standards. Specify sound exposure work cycle rating dba in the "NOTES/COMMENTS" section below.
NOTES/COMMENTS: N.I. 74 DBA			

O. RADIO FREQUENCY SHIELDING - CAUTION!!!

YES	NO	NO & PROVIDE ALTERNATIVE	
X			1. The loader and/or installed components and equipment shall be compatible with use of NDOT mobile and/or two-way communication devices. Main communication radio operates in low band range of

X			forty-seven (47) MHz to forty-eight (48) MHz, but all frequencies apply including low band, high band, UHF, and VHF.
X			2. The loader and/or installed components and equipment shall be manufactured to meet all current SAE and/or ISO Standards applicable and/or relevant to electromagnetic Compatibility.
X			3. NDOT will conduct testing of radio/two-way when installed in chassis.
X			4. NDOT will notify bidder if normal operational parameters are not met due to degradation of signals caused by electromagnetic emissions from chassis or installed components and equipment.
X			5. Bidder shall be required to work with NDOT personnel to reduce interference level to a point acceptable to NDOT normal radio operating parameters.
X			6. Bidder shall have thirty (30) days to resolve radio frequency issue.
X			7. Bidder and/or manufacturer will be responsible for any and all cost to replace and/or modify any parts found to cause radio frequency interference.
X			8. If NDOT and awarded bidder cannot resolve source of radio frequency issue the unit will be sent to an independent accredited lab for testing to ensure SAE and/or ISO Standards compliance.
X			9. Testing shall be done to SAE and/or ISO Standards which are current at date of bid.
X			10. Should the loader and/or installed components and equipment fail testing at the accredited lab, the awarded bidder shall be responsible for all cost incurred for testing.
X			11. If after testing by NDOT and/or accredited lab, the awarded bidder is unable or unwilling to incur the cost and correct the radio frequency issue to the satisfaction of NDOT, all orders and corresponding contract will be canceled.
NOTES/COMMENTS:			

P. MANUALS

YES	NO	NO & PROVIDE ALTERNATIVE	
X			1. All manuals, whether for core or optional items, shall accompany each unit upon delivery.
X			2. An Operator's Manual or CD ROM should accompany each unit upon delivery.
X			a. If the Operator's Manual is available online the State must be able to access it free of charge for fifteen (15) years.
X			3. An Equipment Shop Repair Manual or CD ROM should accompany each unit upon delivery.
X			b. If the Equipment Shop Repair Manual is available online the State must be able to access it free of charge for fifteen (15) years.
X			4. An Engine Shop Repair Manual or CD ROM should accompany each unit upon delivery.
X			a. If the Engine Shop Repair Manual is available online the State must be able to access it free of charge for fifteen (15) years.
X			5. An Equipment Parts Manual or CD ROM should accompany each unit upon delivery.
X			a. If the Equipment Parts Manual is available online the State must be able to access it free of charge for fifteen (15) years.
X			6. An Engine Parts Manual or CD ROM should accompany each unit upon delivery.
X			a. If the Engine Parts Manual is available online the State must be able to access it free of charge for fifteen (1) years.
X			7. All manuals should be furnished upon delivery. Per Neb. Rev. Stat. 81-2403 Goods or service; payment in full; when required (3) "no goods or services shall be deemed to be received by an agency until all such goods or services are completely delivered and finally

X			accepted by the agency....". Thus, payment will not be made until the unit and all required documents are received.
NOTES/COMMENTS:			

Q. MISCELLANEOUS

YES	NO	NO & PROVIDE ALTERNATIVE	
X			1. The bidders should submit with their bid a list of any special tools they will furnish with each unit.
X			2. Dealer's decals, stickers or other signs shall not be affixed to units.
X			3. Dealer's pre-delivery service required.
X			4. Manufacturer's standard yellow color.
X			5. Prior to the awarding of, or entering into any agreement or contract, it shall be the responsibility of the manufacturer and/or the successful bidder to warrant to the State of Nebraska, in writing, that it has factory authorized dealers in the State of Nebraska who will provide warranty/service and repair work without undue delay.
NOTES/COMMENTS:			

R. TRAINING

YES	NO	NO & PROVIDE ALTERNATIVE	
X			1. Minimum of four (4) hours per loader at various locations throughout Nebraska by a factory trained representative in the operation and maintenance of loader. Fleet Management will contact awarded bidder on schedule and places for this training.
NOTES/COMMENTS:			

S. SPECIFICATION FORM(S)

YES	NO	NO & PROVIDE ALTERNATIVE	
X			1. Specification form(s) will be supplied by NDOT to the awarded bidder after a purchase order has been issued. The awarded bidder will be required to complete specification form to the fullest extent possible for each unit and must accompany each unit when delivered.
X			2. If bidder does not properly complete required form(s) for each unit, per Neb. Rev. Stat. 81-2403 Goods or service; payment in full; when required (3) "no goods or services shall be deemed to be received by an agency until all such goods or services are completely delivered and finally accepted by the agency....". Thus, payment will not be made until the unit and all required form(s) are received.
NOTES/COMMENTS:			

T. ANNUAL USAGE, ESTIMATED

YES	NO	NO & PROVIDE ALTERNATIVE	
X			1. Annual usage figures provided are estimates and are not to be construed as either a minimum or maximum purchase quantity.
X			2. The orders shall be for the actual quantities of each item ordered by or for any agency during the life of the contract.
X			3. Bidder shall not impose minimum order requirements.
X			4. The estimated annual usage of the Articulated AWD Loader with Minimum 2.7 CY Bucket is two (2) each.

U. USAGE REPORT

YES	NO	NO & PROVIDE ALTERNATIVE	
X			1. The bidder shall, upon request at any time by the State as determined by the State, provide a usage report of this contract by state agencies and political subdivisions. Information will include, but is not limited to, agency/political subdivision name, item name, item number and dollar amount.
NOTES/COMMENTS:			

V. DELIVERY ARO

YES	NO	NO & PROVIDE ALTERNATIVE	
	X	180	1. Delivery desired within ninety (90) to one-hundred twenty (120) days ARO(s).
NOTES/COMMENTS: V. I. 180 Days			

W. DELIVERY LOCATION

YES	NO	NO & PROVIDE ALTERNATIVE	
X			1. NDOT 5001 S 14 th Street Lincoln, NE 68512
NOTES/COMMENTS:			

X. ORDERS

YES	NO	NO & PROVIDE ALTERNATIVE	
X			1. Orders will be placed by e-mail. To the contractor awarded.
X			2. All orders must reference a purchase order number and
X			3. the purchase order number must be referenced on the packing slip, and invoice.
X			4. Invoices are to be sent to the "Invoice to" address on the purchase order.

NOTES/COMMENTS:

Y. QUALITY

YES	NO	NO & PROVIDE ALTERNATIVE	
X			1. Product quality must meet specifications and be consistent for the term of the contract. All materials must be of first quality, under standard production by the manufacturer and be of standard design, complete as regularly advertised and marketed and be of proven performance.
X			2. A guarantee of satisfactory performance by the bidder and meeting delivery dates are an integral part of the purchase contract resulting from this bid.
X			3. Products are to be fully guaranteed and may be returned for full credit or replacement (at the State's option) for any reason during the initial warranty period with no additional charges for shipping or restocking.
NOTES/COMMENTS:			

Z. WARRANTY

YES	NO	NO & PROVIDE ALTERNATIVE	
X			1. Manufacturer's usual warranty shall apply and shall be in effect for at least one (1) year from the date the equipment was placed in service by purchasing entity.
X			2. Bidder should supply warranty information with bid.
X			3. Bidder shall be responsible for all repairs to include parts, labor and machine transportation cost during the twelve (12) month usual warranty period.
X			4. The power train and engine shall be warranted for additional five (5) years.
X			5. These guarantees are in addition to the standard twelve (12) month warranty and do not have any effect upon the standard warranty.
X			a. If the engine is not produced by the loader manufacturer, the bidder will guarantee that the engine will be repaired by a certified and registered engine warranty dealer or distributorship.
X			6. The following power train components are warranted to be free from defects in workmanship and material during the extended warranty period:
X			a. Engine (excluding radiator, alternator, starter, compressor, and other attachments).
X			b. Torque converter (if applicable), transmission.
X			c. Drive shafts and Universal joints.
X			d. Differential.
X			e. Transfer gear group.
X			f. Drive axles.
X			g. Drive pumps.
X			h. Drive motors.
X			i. Pinion and bevel gear.
X			j. Final drive gear train.
X			k. Computerized and electronic equipment.

X			7. This warranty is limited to repair or replacement (including both parts and Labor) of inspected parts determined to have been defective in material or workmanship. All extended power train warranty repairs will be performed by manufacturer's authorized service personnel. All machine transportation cost to and from the nearest authorized bidder repair facility and travel time and mileage during the extended warranty period will be responsibility of the bidder and/or manufacturer. This warranty does not apply to normal maintenance service (such as engine tune-up) or normal replacement of service or wear items.
X			8. Any oil sampling or other necessary testing needed to implement this warranty must be included in writing with this bid. The NDOT will do oil sampling if required by the manufacturer, but all materials must be furnished at no charge to the Department. A written report will be returned to NDOT if sampling is required.
X			9. This extended coverage is subject to the following conditions and limitations.
X			a. Replacement parts provided are warranted for the remainder of the extended warranty period applicable to the product in which installed.
X			b. The machine may not be altered or modified in any manner which affects the mechanical operation as designed with written permission from the NDOT.
X			10. The following limitations shall be applicable to all guarantees.
X			a. Parts ordering and machine repair requests will occur during dealer's normal working hours.
X			b. The parts and machine repair guarantees will not apply to machines which have been substantially damaged by collision, accident, flood, fire, vandalism, or similar occurrence.
X			c. The parts and machine repair guarantees will not apply to machines when delay results from strikes (dealer, supplier, or carrier), act of God or other occurrences beyond bidder's reasonable control.
X			11. If machine cannot be repaired within thirty (30) days, a comparable loaner machine will be furnished to the State of Nebraska at no cost during the warranty period.
NOTES/COMMENTS:			

AA. AUTHORIZED DEALER & WARRANTY

YES	NO	NO & PROVIDE ALTERNATIVE	
X			1. To the extent required by the manufacturer, the Bidder shall be an authorized dealer. Bidder may be required to substantiate that he/she is an authorized dealer. Proof, if required, must be submitted to SPB within three (3) business days of the request and prior to the award of any contract.
X			2. The terms of the original manufacturer's standard warranty shall apply to all equipment acquired from this bid for the entire warranty period.
X			3. Bidder shall provide a list of approved OEM service, repair & parts locations in the State of Nebraska or within a 4-hour response time. Provide information in the "NOTES/COMMENTS" section below or attach list
X			4. Bidder shall provide a list of approximate number and locations of OEM Trained and/or certified service technicians in the state of Nebraska or in a 4-hour response time. Provide information in the "NOTES/COMMENTS" section below or attach list
NOTES/COMMENTS: See Attachment AA. 3+4. Authorized Dealer + Warranty Murphy Tractor Locations.			

VII. OPTIONS

A. QUICK HITCH WITH SPECIFIED BUCKET

YES	NO	NO & PROVIDE ALTERNATIVE	
X			1. Quick hitch (coupler) system with bucket equivalent to bucket specified in Section VI, Subsection H-LOADER.
X			2. The manufacturer's loader and the factory bucket will be replaced by the quick hitch and bucket.
X			3. Acceptable brands are JRB, ACS or loader manufacturer's model. Please specify which brand you are bidding in the "NOTES/COMMENTS" section below.
X			4. The securing pins controls in the cab will hydraulically operate from loader's existing hydraulics.
X			5. Quick hitch and specified bucket must be recommended by the manufacturer for the loader bid.
<p>NOTES/COMMENTS: A. 3. John Deere compatible with JRB 416.</p>			

B. QUICK ATTACH FORKLIFT ASSEMBLY

YES	NO	NO & PROVIDE ALTERNATIVE	
X			1. Forklift assembly to be quick attach style and match the quick hitch with specified bucket.
X			2. Quick hitch shall be JRB, ACS or loader manufacturer OEM supplied hitch.
X			3. Carriage width to be minimum fifty-three inches (53").
X			4. Tine length to be minimum sixty inches (60").
X			5. Manually adjustable tines of two- and one-half inch (2.5") X six inch (6").
X			6. Minimum Load Capacity of 10,000 pounds at twenty-four-inch (24") load center.
<p>NOTES/COMMENTS:</p>			

C. MULTI-PURPOSE BUCKET

YES	NO	NO & PROVIDE ALTERNATIVE	
X			1. The factory furnished bucket will be replaced by the multi-purpose bucket.
X			2. The multi-purpose bucket shall be at a minimum as heavy duty as the manufacturer's loader normally furnished bucket.
X			3. Any additional valves, hydraulics, hoses, etc. will be furnished.
X			4. The unit for the proposed loader bucket shall be as recommended by the manufacturer.
<p>NOTES/COMMENTS:</p>			

D. GRAPPLE FORK ATTACHMENT

YES	NO	NO & PROVIDE ALTERNATIVE	
X			1. Grapple fork to GrabTec "GA" series or equivalent to be mounted to bucket as specified in Section VI, Subsection H-LOADER.
X			2. Grapple fork is to be installed on the bucket upon delivery.
X			3. Any costs incurred, including any transportation costs, to have the grapple fork mounted to the specified bucket shall be the responsibility of the awarded bidder.
X			4. Grapple assembly to be of a Quick Attach Style:
X			a. Install weight of grapple assembly to be minimum 1,200 pounds.
X			b. Hydraulic cylinder bore to be a minimum three inches (3").
X			c. Hydraulic hoses of adequate length with couplers shall be provided. The hoses shall be coupled to the loader's auxiliary circuit (Third Valve)
X			d. Fork teeth material to be minimum one inch (1") thick.
X			e. Teeth to be replaceable. Minimum of five (5) teeth per assembly.
X			f. Clamping force of fork assembly to be approximately 10,000 pounds rated with cylinder pressure of 3,750 psi.
X			g. Opening of forks measured from ground level to tip of teeth to be approximately eighty-six inches (86").
X			5. Any additional hydraulic valve hoses, excluding the auxiliary third valve, etc. to be furnished by the bidder.
X			6. Attachment shall carry a one (1) year warranty to be provided by the fork manufacturer or by the awarded bidder.
NOTES/COMMENTS:			

E. WHEEL LOADER SCALE SYSTEM

YES	NO	NO & PROVIDE ALTERNATIVE	
X			1. Scale system to be Loup Electronics Weighlog 8000T or equivalent and shall be installed and calibrated on loader.
X			2. Optional in-cab printer.
X			3. Hydraulic pressure sensors.
X			4. Reference and direction sensor.
NOTES/COMMENTS:			

MURPHY

TRACTOR & EQUIPMENT CO.

PO BOX 460
GERING, NE 69341-0460
308-436-2177

3204 S ENGLEMAN RD
GRAND ISLAND, NE 68803-6621
308-381-0741

6100 ARBOR RD
LINCOLN, NE 68517-3211
402-467-1300

PO BOX 1013
NORTH PLATTE, NE 69103-1013
308-534-7020

9751 S 148TH ST
OMAHA, NE 68138-3898
402-894-1899

PO BOX 5349
SIOUX CITY, IA 51102-5349
712-252-2753

CORPORATE OFFICE:

5375 N DEERE RD
PARK CITY, KS 67219-3307
316-945-1015

Gering 6

220810 Highway 92
Gering, NE 69341-5236
308-436-2177 784

PO Box 460
69341-0460

Joe Blanke, Branch Manager 308-631-5874
Tony Brown, Service Manager 308-631-8682
tbrown@murphytractor.com
Casey Rau, Parts Manager 308-765-9884
crau@murphytractor.com

Omaha 7

9751 S 148th St
Omaha, NE 68138-3898
402-894-1899 Mary Kostka
402-891-8360 Fax
800-416-5095

Barry Spencer, Branch Manager 402-981-4400
Kash Buresh, Service Manager 402-953-7374
Kburesh@murphytractor.com
Jana Cornish, Parts Manager 402-677-4589
jcornish@murphytractor.com
Doug Jacobson Wirtgen Prod Supp Mgr. -
402-416-7174

Lincoln 8

6100 Arbor Rd
Lincoln, NE 68517-3211
402-467-1300 Shaunna Walker
402-467-1927 Fax
800-416-5518
Greg Kozisek, Branch Mgr. 402-432-6946
Jase Breece, Service Manager 402-326-9740
jbreece@murphytractor.com
Alexah Allen, Parts Manager 402-430-0282
aallen@murphytractor.com

Grand Island 9

3204 S Engleman Rd
Grand Island, NE 68803-6621

308-381-0741 Natalie Foulk
308-381-2051 Fax
800-868-4017
Jordan Mrkvicka, Branch Mgr. 308-218-7421
jwilliams@murphytractor.com
Justin Groff, Parts Manager 308-379-0380
jgroff@murphytractor.com

MURPHY

TRACTOR & EQUIPMENT CO.

PO BOX 460
GERING, NE 69341-0460
308-436-2177

3204 S ENGLEMAN RD
GRAND ISLAND, NE 68803-6621
308-381-0741

6100 ARBOR RD
LINCOLN, NE 68517-3211
402-467-1300

PO BOX 1013
NORTH PLATTE, NE 69103-1013
308-534-7020

9751 S 148TH ST
OMAHA, NE 68138-3898
402-894-1899

PO BOX 5349
SIOUX CITY, IA 51102-5349
712-252-2753

CORPORATE OFFICE:

5375 N DEERE RD
PARK CITY, KS 67219-3307
316-945-1015

jwilliams@murphytractor.com
Justin Groff, Parts Manager 308-379-0380
jgroff@murphytractor.com

North Platte 11

3701 S Jeffers St PO Box 1013
North Platte, NE 69101-7844 69103-1013
308-534-7020Shelly Kerchal
308-534-7022 Fax
800-894-7060

Joleen Schauer, Branch Mgr. 308-530-2730
Ken Rice, Service Manager 308-530-7570
krice@murphytractor.com
Justin Stutzman Parts Mgr 308-520-1022
jstutzman@murphytractor.com

Sioux City 16

4900 Harbor Dr
Sioux City, IA 51111-1106
712-252-2753 Gate Combs
712-252-0352 Fax
Cole Knapp Branch Mgr. 712-251-6622
Dan Nelson Service Manager 712-635-0175
dnelson@murphytractor.com
Jeff Olesen Parts Manager 712-251-5994
jolesen@murphytractor.com

MURPHY TRACTOR'S CERTIFIED SERVICE TECHNICIANS

36 CERTIFIED FIELD TECHNICIANS
40 CERTIFIED SHOP TECHNICIANS

544 G

Wheel Loader



JOHN DEERE



544 G-TIER WHEEL LOADER

GET DOWN TO BUSINESS

Got a material-handling task that demands impressive machine agility and ability? The John Deere 544 G-Tier Wheel Loader is packed with proven capabilities plus customer-inspired productivity- and uptime-enhancing features. This mid-sized machine delivers rugged reliability and outsized operating ease, just like the rest of the legendary Deere loader lineup. And its lower initial acquisition cost doesn't mean equipment quality and dealer support are in short supply. Get ready to realize what this purpose-built model can help your operation do.



FEATURES

Machine and fleet versatility

Choose between optional pin-on buckets and Hi-Vis/ISO- and JRB-style couplers that accept L- and K-Series as well as P- and X-tier attachments and buckets. Optional third- and fourth-function hydraulics enable the use of a broad range of attachments. Available field kits allow fork frames and other bucket options to be added.

Comfort and control in the cab

Easy-to-access machine settings and features, adjustable high-definition monitor with built-in diagnostic trouble codes, and convenient floor storage help operators work productively. Durable joystick controls, foot pedals, and sealed-switch module (SSM) are ergonomically placed. The choice of standard mechanical or optional air-ride suspension seat is yours.

User-friendly operation

Intuitive pilot controls and the automatic transmission that shifts on the fly can be appreciated by both novice and skilled operators. Optional front-differential lock stabilizes traction in muddy or soft ground conditions. In-cab adjustable boom-height kickout, return to carry, and return to dig can be easily activated from the SSM, speeding repetitive applications. Clutch cutoff delivers full engine power to the hydraulics when crowding a pile and using the brakes, decreasing cycle times and boosting productivity.

Let it snow

Contractors and governmental agencies can specifically benefit from using the 544 G-Tier Loader for snow-removal tasks. Snow tires, couplers, beacons, and fourth-function hydraulics are available from the factory to equip your machine to handle the white stuff.



RELIABLE

+



SIMPLE TO
SERVICE

FIND YOUR FIT



LEADING EDGE

Premium edge with innovative technology



EXCEPTIONAL PERFORMANCE

Advanced features and performance



RUGGED AND RELIABLE

Proven capabilities and value

Reach for more

For extra reach when loading trucks, hoppers, or feed mixers, adding High-Lift linkage provides an extra 14 inches of hinge-pin height over standard linkage.

Economical high performer

The John Deere 544 G-Tier Wheel Loader was designed to deliver a lower cost of ownership solution without sacrificing performance compared to 544 and 524 P-Tier models.

Proven design and reliability

The 544 G-tier leverages components and technology similar to those featured in both our current and previous series loaders for decades. John Deere PowerTech™ 6.8L engine is designed to maximize cooling efficiency and cylinder and piston-ring durability. John Deere TeamMate™ V axles contain pressure-lubed input bearings and brake discs to boost wear life. Extended service intervals lower maintenance costs over the life of the machine. Auto-idle and auto shutdown reduce engine speed or turn it off after a period of inactivity to save fuel and warranty hours.

Dependable service and support

Renowned John Deere and dealer support, parts availability, and warranty help keep your equipment up and running. All daily service points including fuel are conveniently grouped at ground level on the left side of the machine. Sight gauges for transmission and hydraulic fluid levels are easy to read. Hinged doors provide wide-open access to the engine, cooling system, and other components.



**JOBSITE
PROVEN**

+



**EASY TO
OPERATE**



544 G-TIER WHEEL LOADER

Remote diagnostics and support

To maximize uptime and lower costs, JDLink™ connectivity provides machine location, utilization data, and alerts to help you maximize productivity and efficiency. JDLink also enables John Deere Connected Support™. Dealers use Expert Alerts based on data from thousands of connected machines to proactively address conditions that may otherwise likely lead to downtime. Your dealer can also monitor machine health and leverage remote diagnostics and programming capability to further diagnose problems and even update machine software without a time-consuming trip to the jobsite.*

*Availability varies by region. Options not available in every country.



544 G-TIER WHEEL LOADER SPECIFICATIONS

While general information, pictures, and descriptions are provided, some illustrations and text may include product options and accessories NOT AVAILABLE in all regions, and in some countries products and accessories may require modifications or additions to ensure compliance with the local regulations of those countries.

Engine	544 G Z-BAR / HIGH-LIFT TIER 3		544 G Z-BAR / HIGH-LIFT FINAL TIER 4 (FT4)	
Manufacturer and Model	John Deere PowerTech™ E 6068H		John Deere PowerTech™ PVS 6068	
Non-Road Emission Standard	EPA Tier 3/EU Stage IIIA		EPA FT4/EU Stage V	
Cylinders	6		6	
Valves Per Cylinder	2		4	
Displacement	6.8 L (414 cu. in.)		6.8 L (414 cu. in.)	
Net Peak Power (ISO 9249)	124 kW (166 hp) at 1,900 rpm		125 kW (168 hp) at 1,800 rpm	
Net Peak Torque (ISO 9249)	669 Nm (493 lb.-ft.) at 1,600 rpm		696 Nm (513 lb.-ft.) at 1,100 rpm	
Net Torque Rise	36%		40%	
Fuel System (electronically controlled)	High-pressure common rail		High-pressure common rail	
Lubrication	Full-flow spin-on filter and integral cooler		Full-flow spin-on filter and integral cooler	
Aspiration	Turbocharged, charge air cooled		Turbocharged, charge air cooled	
Air Cleaner	Under-hood, dual-element dry type, restriction indicator in cab monitor for service			
Cooling	544 G Z-BAR / HIGH-LIFT TIER 3 / FT4			
Fan Drive	Hydraulically driven, proportionally controlled, fan aft of coolers			
Electrical	544 G Z-BAR / HIGH-LIFT TIER 3		544 G Z-BAR / HIGH-LIFT FT4	
Electrical System	24 volt with 80-amp alternator		24 volt with 100-amp alternator	
Batteries (2 – 12 volt)	950 CCA (each)		950 CCA (each)	
Transmission System				
Type	Countershaft-type PowerShift		Countershaft-type PowerShift	
Torque Converter	Single stage, single phase		Single stage, single phase	
Shift Control	Electronically modulated, adaptive, load and speed dependent		Electronically modulated, adaptive, load and speed dependent	
Operator Interface	Joystick-mounted F-N-R; Quick-Shift button on hydraulic lever		Joystick-mounted F-N-R; Quick-Shift button on hydraulic lever	
Shift Modes	Manual/auto (1st–D or 2nd–D); Quick-Shift button with 2 selectable modes: kick-down or kick-up/down; and 3 adjustable clutch cutoff settings			
Maximum Travel Speeds (with 20.5 R 25 tires)	<i>Forward</i>	<i>Reverse</i>	<i>Forward</i>	<i>Reverse</i>
Range 1	5.6 km/h (3.5 mph)	5.9 km/h (3.7 mph)	5.6 km/h (3.5 mph)	5.9 km/h (3.7 mph)
Range 2	11.0 km/h (6.8 mph)	11.6 km/h (7.2 mph)	11.0 km/h (6.8 mph)	11.6 km/h (7.2 mph)
Range 3	16.8 km/h (10.4 mph)	25.5 km/h (15.8 mph)	16.7 km/h (10.4 mph)	25.5 km/h (15.8 mph)
Range 4	24.1 km/h (15.0 mph)	N/A	24.0 km/h (14.9 mph)	N/A
Range 5	35.8 km/h (22.2 mph)	N/A	35.9 km/h (22.3 mph)	N/A
Axles/Brakes	544 G Z-BAR / HIGH-LIFT TIER 3 / FT4			
Final Drives	Heavy-duty inboard-mounted planetary			
Differentials	Hydraulic locking front with conventional rear – standard; dual conventional front and rear – optional			
Rear Axle Oscillation, Stop to Stop (with 20.5 R 25 tires)	24 deg. (12 deg. each direction)			
Brakes (conform to ISO 3450)				
Service	Hydraulically actuated, spring retracted, self-adjusting, inboard sun-shaft mounted, oil cooled, single disc			
Parking	Automatic spring applied, hydraulically released, driveline mounted, sealed wet multi disc			
Tires/Wheels				
(see pages 9–10 for complete tire adjustments)	544 G Z-BAR / HIGH-LIFT TIER 3		544 G Z-BAR / HIGH-LIFT FT4	
	<i>Tread Width</i>	<i>Width Over Tires</i>	<i>Tread Width</i>	<i>Width Over Tires</i>
Advance 20.5 – 25, 16PR L-3	1950 mm (76.8 in.)	2470 mm (97.2 in.)	N/A	N/A
Advance 20.5 R25, 2 Stars L-3	N/A	N/A	1950 mm (76.8 in.)	2460 mm (96.9 in.)
Serviceability				
Refill Capacities				
Fuel Tank	290 L (76.6 gal.)		290 L (76.6 gal.)	
Diesel Exhaust Fluid (DEF)	N/A		15.7 L (16.6 qt.)	
Engine Cooling System	26.2 L (27.7 qt.)		34.9 L (36.9 qt.)	
Engine Oil With Vertical Spin-On Filter	19 L (20 qt.)		19.5 L (20.6 qt.)	
Transmission Reservoir With Vertical Filter	18 L (19 qt.)		18 L (19 qt.)	
Axle Oil (front and rear, each)				
Front	15 L (15.9 qt.)		15 L (15.9 qt.)	
Rear	16.3 L (17.2 qt.)		16.3 L (17.2 qt.)	
Hydraulic Reservoir and Filter	86 L (22.7 gal.)		86 L (22.7 gal.)	
Park Brake Oil (wet disc)	0.3 L (10 oz.)		0.3 L (10 oz.)	
Hydraulic System/Steering	544 G Z-BAR / HIGH-LIFT TIER 3 / FT4			
Pump (loader and steering)	Variable-displacement, axial-piston pump; closed-center, pressure-compensating system			
Maximum Rated Flow at 6895 kPa (1000 psi) and 2,350 rpm	189 L/m (50 gpm)			
System Relief Pressure (loader and steering)	25 166 kPa (3,650 psi)			
Loader Controls	2-function valve; joystick control or fingertip controls (field kit); hydraulic-function enable/disable; optional 3rd- and 4th-function valve with auxiliary lever			
Steering (conforms to ISO 5010)	Steering-column mounted			
Type	Power, fully hydraulic			
Articulation Angle	80-deg. arc (40 deg. each direction)			

544 G-TIER WHEEL LOADER SPECIFICATIONS

544

G

While general information, pictures, and descriptions are provided, some illustrations and text may include product options and accessories NOT AVAILABLE in all regions, and in some countries products and accessories may require modifications or additions to ensure compliance with the local regulations of those countries.

Hydraulic System/Steering (continued)	544 G Z-BAR / HIGH-LIFT	
	TIER 3	FT4
Turning Radius (measured to centerline of outside tire)	5.00 m (16 ft. 5 in.)	5.00 m (16 ft. 5 in.)
Hydraulic Cycle Times		
Raise	5.7 sec.	5.8 sec.
Dump	1.3 sec.	1.3 sec.
Lower (float down)	3.4 sec.	3.4 sec.
Total	10.4 sec.	10.5 sec.

Dimensions and Specifications With Pin-On Bucket With Bolt-On Edge

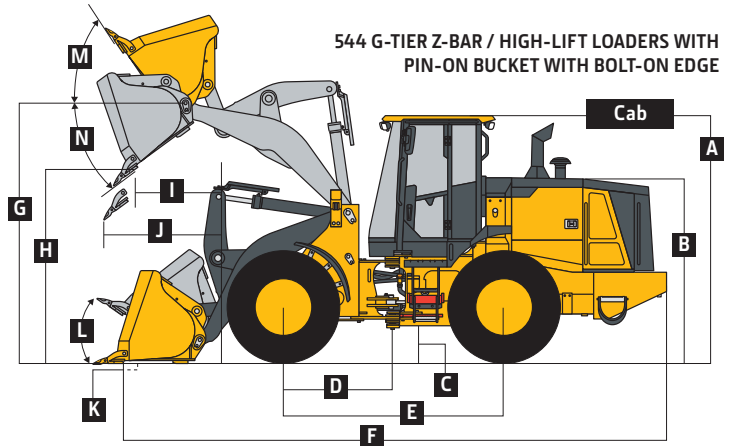

544 G-TIER Z-BAR / HIGH-LIFT LOADERS WITH PIN-ON BUCKET WITH BOLT-ON EDGE

Key: General-Purpose (GP)

	544 G Z-Bar Tier 3		544 G High-Lift Tier 3		544 G Z-Bar FT4		544 G High-Lift FT4	
	2.1-m ³ (2.75 cu. yd.) GP	2.3-m ³ (3.00 cu. yd.) GP	2.1-m ³ (2.75 cu. yd.) GP	2.3-m ³ (3.00 cu. yd.) GP	2.1-m ³ (2.75 cu. yd.) GP	2.3-m ³ (3.00 cu. yd.) GP	2.1-m ³ (2.75 cu. yd.) GP	2.3-m ³ (3.00 cu. yd.) GP
Dimensions With Bucket With Bolt-On Edge (illustration above right)								
A Height to Top of Cab	3.27 m (10 ft. 9 in.)	3.27 m (10 ft. 9 in.)	3.27 m (10 ft. 9 in.)	3.27 m (10 ft. 9 in.)	3.27 m (10 ft. 9 in.)	3.27 m (10 ft. 9 in.)	3.27 m (10 ft. 9 in.)	3.27 m (10 ft. 9 in.)
B Hood Height	2.43 m (7 ft. 11 in.)	2.43 m (7 ft. 11 in.)	2.43 m (7 ft. 11 in.)	2.43 m (7 ft. 11 in.)	2.43 m (7 ft. 11 in.)	2.43 m (7 ft. 11 in.)	2.43 m (7 ft. 11 in.)	2.43 m (7 ft. 11 in.)
C Ground Clearance	0.41 m (16.1 in.)	0.41 m (16.1 in.)	0.41 m (16.1 in.)	0.41 m (16.1 in.)	0.41 m (16.1 in.)	0.41 m (16.1 in.)	0.41 m (16.1 in.)	0.41 m (16.1 in.)
D Length From Centerline to Front Axle	1.45 m (4 ft. 9 in.)	1.45 m (4 ft. 9 in.)	1.45 m (4 ft. 9 in.)	1.45 m (4 ft. 9 in.)	1.45 m (4 ft. 9 in.)	1.45 m (4 ft. 9 in.)	1.45 m (4 ft. 9 in.)	1.45 m (4 ft. 9 in.)
E Wheelbase	2.93 m (9 ft. 7 in.)	2.93 m (9 ft. 7 in.)	2.93 m (9 ft. 7 in.)	2.93 m (9 ft. 7 in.)	2.93 m (9 ft. 7 in.)	2.93 m (9 ft. 7 in.)	2.93 m (9 ft. 7 in.)	2.93 m (9 ft. 7 in.)
F Overall Length, Bucket on Ground	7.47 m (24 ft. 6 in.)	7.56 m (24 ft. 9 in.)	7.80 m (25 ft. 7 in.)	7.88 m (25 ft. 10 in.)	7.47 m (24 ft. 6 in.)	7.56 m (24 ft. 10 in.)	7.80 m (25 ft. 7 in.)	7.88 m (25 ft. 10 in.)
G Height to Hinge Pin, Fully Raised	3.83 m (12 ft. 7 in.)	3.83 m (12 ft. 7 in.)	4.19 m (13 ft. 9 in.)	4.19 m (13 ft. 9 in.)	3.83 m (12 ft. 7 in.)	3.83 m (12 ft. 7 in.)	4.18 m (13 ft. 9 in.)	4.18 m (13 ft. 9 in.)
H Dump Clearance, 45 deg., Full Height	2.84 m (9 ft. 4 in.)	2.78 m (9 ft. 1 in.)	3.19 m (10 ft. 5 in.)	3.13 m (10 ft. 3 in.)	2.84 m (9 ft. 4 in.)	2.78 m (9 ft. 1 in.)	3.19 m (10 ft. 5 in.)	3.13 m (10 ft. 3 in.)
I Reach, 45-deg. Dump, Full Height	0.92 m (3 ft. 0 in.)	0.98 m (3 ft. 2 in.)	0.92 m (3 ft. 0 in.)	0.98 m (3 ft. 2 in.)	0.93 m (3 ft. 1 in.)	0.99 m (3 ft. 3 in.)	0.93 m (3 ft. 1 in.)	0.99 m (3 ft. 3 in.)
J Reach, 45-deg. Dump, 2.13-m (7 ft. 0 in.) Clearance	1.44 m (4 ft. 9 in.)	1.46 m (4 ft. 10 in.)	1.73 m (5 ft. 8 in.)	1.76 m (5 ft. 9 in.)	1.44 m (4 ft. 9 in.)	1.47 m (4 ft. 10 in.)	1.74 m (5 ft. 8 in.)	1.77 m (5 ft. 10 in.)
K Maximum Digging Depth	80 mm (3.1 in.)	87 mm (3.4 in.)	161 mm (6.4 in.)	168 mm (6.6 in.)	80 mm (3.2 in.)	87 mm (3.4 in.)	162 mm (6.4 in.)	169 mm (6.6 in.)
L Maximum Rollback at Ground Level	42 deg.	42 deg.	37 deg.	37 deg.	42 deg.	42 deg.	37 deg.	37 deg.
M Maximum Rollback, Boom Fully Raised	55 deg.	55 deg.	50 deg.	50 deg.	55 deg.	55 deg.	50 deg.	50 deg.
N Maximum Bucket Dump Angle, Fully Raised	49 deg.	49 deg.	45 deg.	45 deg.	49 deg.	49 deg.	45 deg.	45 deg.
Loader Clearance Circle, Bucket Carry Position	11.57 m (37 ft. 11 in.)	11.62 m (38 ft. 1 in.)	11.88 m (39 ft. 0 in.)	11.94 m (39 ft. 2 in.)	11.57 m (38 ft. 0 in.)	11.62 m (38 ft. 1 in.)	11.88 m (39 ft. 0 in.)	11.94 m (39 ft. 2 in.)
Specifications With Bucket With Bolt-On Edge								
Capacity, Heaped	2.1 m ³ (2.75 cu. yd.)	2.3 m ³ (3.0 cu. yd.)	2.1 m ³ (2.75 cu. yd.)	2.3 m ³ (3.0 cu. yd.)	2.1 m ³ (2.75 cu. yd.)	2.3 m ³ (3.0 cu. yd.)	2.1 m ³ (2.75 cu. yd.)	2.3 m ³ (3.0 cu. yd.)
Capacity, Struck	1.7 m ³ (2.2 cu. yd.)	2.0 m ³ (2.6 cu. yd.)	1.7 m ³ (2.2 cu. yd.)	2.0 m ³ (2.6 cu. yd.)	1.7 m ³ (2.2 cu. yd.)	2.0 m ³ (2.6 cu. yd.)	1.7 m ³ (2.2 cu. yd.)	2.0 m ³ (2.6 cu. yd.)
Bucket Weight With Bolt-On Cutting Edge	1014 kg (2,235 lb.)	1070 kg (2,359 lb.)	1014 kg (2,235 lb.)	1070 kg (2,359 lb.)	1014 kg (2,235 lb.)	1070 kg (2,359 lb.)	1014 kg (2,235 lb.)	1070 kg (2,359 lb.)
Bucket Width	2.55 m (8 ft. 4 in.)		2.55 m (8 ft. 4 in.)		2.55 m (8 ft. 4 in.)		2.55 m (8 ft. 4 in.)	
Breakout Force	10 916 kg (24,066 lb.)	10 114 kg (22,299 lb.)	10 092 kg (22,248 lb.)	9348 kg (20,609 lb.)	10 916 kg (24,067 lb.)	10 115 kg (22,299 lb.)	10 092 kg (22,250 lb.)	9349 kg (20,611 lb.)
Tipping Load, Straight, No Tire Deflection	11 220 kg (24,735 lb.)	11 085 kg (24,439 lb.)	9591 kg (21,144 lb.)	9463 kg (20,863 lb.)	11 271 kg (24,849 lb.)	11 136 kg (24,552 lb.)	9673 kg (21,326 lb.)	9545 kg (21,044 lb.)
Tipping Load, Straight, With Tire Deflection	10 608 kg (23,387 lb.)	10 470 kg (23,082 lb.)	9123 kg (20,113 lb.)	8994 kg (19,828 lb.)	10 668 kg (23,519 lb.)	10 530 kg (23,215 lb.)	9210 kg (20,305 lb.)	9081 kg (20,020 lb.)
Tipping Load, 40-deg. Full Turn, No Tire Deflection	9701 kg (21,388 lb.)	9577 kg (21,113 lb.)	8269 kg (18,231 lb.)	8151 kg (17,970 lb.)	9770 kg (21,540 lb.)	9646 kg (21,265 lb.)	8363 kg (18,437 lb.)	8244 kg (18,175 lb.)
Tipping Load, 40-deg. Full Turn, With Tire Deflection	8919 kg (19,663 lb.)	8793 kg (19,385 lb.)	7662 kg (16,892 lb.)	7542 kg (16,627 lb.)	9003 kg (19,848 lb.)	8874 kg (19,564 lb.)	7767 kg (17,123 lb.)	7644 kg (16,852 lb.)
Rated Operating Load, 50% Full-Turn Tipping Load, No Tire Deflection (conforms to ISO 14397-1)*	4851 kg (10,694 lb.)	4788 kg (10,557 lb.)	4135 kg (9,115 lb.)	4075 kg (8,985 lb.)	4885 kg (10,770 lb.)	4823 kg (10,632 lb.)	4181 kg (9,218 lb.)	4122 kg (9,087 lb.)
Rated Operating Load, 50% Full-Turn Tipping Load, With Tire Deflection (conforms to ISO 14397-1)*	4460 kg (9,832 lb.)	4397 kg (9,693 lb.)	3831 kg (8,446 lb.)	3771 kg (8,314 lb.)	4502 kg (9,924 lb.)	4437 kg (9,782 lb.)	3884 kg (8,562 lb.)	3822 kg (8,426 lb.)
Operating Weight	12 688 kg (27,971 lb.)	12 744 kg (28,096 lb.)	12 786 kg (28,189 lb.)	12 843 kg (28,314 lb.)	12 993 kg (28,646 lb.)	13 050 kg (28,771 lb.)	13 116 kg (29,042 lb.)	13 173 kg (29,042 lb.)

Loader operating information is based on machine with identified linkage and standard equipment, John Deere PowerTech E 6068H/PowerTech PVS 6068 engine, ROPS cab, rear cast bumper/counterweight, transmission side-frame guards, bottom guards, standard tires, full fuel tank, and 79-kg (175 lb.) operator. This information is affected by changes in tires, ballast, and different attachments.

*Rated operating capacity based on Deere attachments only.

544 G-TIER

While general information, pictures, and descriptions are provided, some illustrations and text may include product options and accessories NOT AVAILABLE in all regions, and in some countries products and accessories may require modifications or additions to ensure compliance with the local regulations of those countries.

Dimensions and Specifications With Hi-Vis Coupler and Hook-On Bucket With Bolt-On Edge

544 G Z-BAR / HIGH-LIFT TIER 3 / FT4

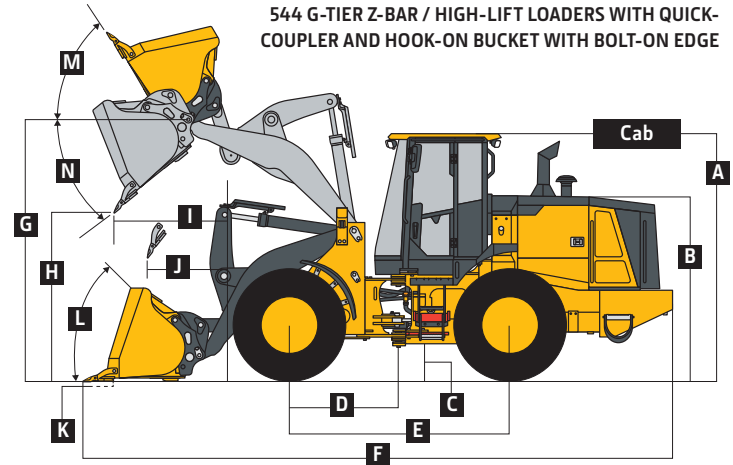

Key: General-Purpose (GP)

	544 G Z-Bar Tier 3		544 G High-Lift Tier 3		544 G Z-Bar FT4		544 G High-Lift FT4	
Dimensions With Bucket With Bolt-On Edge (illustration above right)	2.1-m ³ (2.75 cu. yd.) GP	2.3-m ³ (3.00 cu. yd.) GP	2.1-m ³ (2.75 cu. yd.) GP	2.3-m ³ (3.00 cu. yd.) GP	2.1-m ³ (2.75 cu. yd.) GP	2.3-m ³ (3.00 cu. yd.) GP	2.1-m ³ (2.75 cu. yd.) GP	2.3-m ³ (3.00 cu. yd.) GP
A Height to Top of Cab	3.27 m (10 ft. 9 in.)	3.27 m (10 ft. 9 in.)	3.27 m (10 ft. 9 in.)	3.27 m (10 ft. 9 in.)	3.27 m (10 ft. 9 in.)	3.27 m (10 ft. 9 in.)	3.27 m (10 ft. 9 in.)	3.27 m (10 ft. 9 in.)
B Hood Height	2.43 m (7 ft. 11 in.)	2.43 m (7 ft. 11 in.)	2.43 m (7 ft. 11 in.)	2.43 m (7 ft. 11 in.)	2.43 m (7 ft. 11 in.)	2.43 m (7 ft. 11 in.)	2.43 m (7 ft. 11 in.)	2.43 m (7 ft. 11 in.)
C Ground Clearance	0.41 m (16.1 in.)	0.41 m (16.1 in.)	0.41 m (16.1 in.)	0.41 m (16.1 in.)	0.41 m (16.1 in.)	0.41 m (16.1 in.)	0.41 m (16.1 in.)	0.41 m (16.1 in.)
D Length From Centerline to Front Axle	1.45 m (4 ft. 9 in.)	1.45 m (4 ft. 9 in.)	1.45 m (4 ft. 9 in.)	1.45 m (4 ft. 9 in.)	1.45 m (4 ft. 9 in.)	1.45 m (4 ft. 9 in.)	1.45 m (4 ft. 9 in.)	1.45 m (4 ft. 9 in.)
E Wheelbase	2.93 m (9 ft. 7 in.)	2.93 m (9 ft. 7 in.)	2.93 m (9 ft. 7 in.)	2.93 m (9 ft. 7 in.)	2.93 m (9 ft. 7 in.)	2.93 m (9 ft. 7 in.)	2.93 m (9 ft. 7 in.)	2.93 m (9 ft. 7 in.)
F Overall Length, Bucket on Ground	7.71 m (25 ft. 3 in.)	8.03 m (26 ft. 4 in.)	8.03 m (26 ft. 4 in.)	8.03 m (26 ft. 4 in.)	7.71 m (25 ft. 3 in.)	8.03 m (26 ft. 4 in.)	8.03 m (26 ft. 4 in.)	8.03 m (26 ft. 4 in.)
G Height to Hinge Pin, Fully Raised	3.83 m (12 ft. 7 in.)	4.19 m (13 ft. 9 in.)	4.19 m (13 ft. 9 in.)	4.19 m (13 ft. 9 in.)	3.83 m (12 ft. 7 in.)	4.18 m (13 ft. 9 in.)	4.18 m (13 ft. 9 in.)	4.18 m (13 ft. 9 in.)
H Dump Clearance, 45-deg., Full Height	2.67 m (8 ft. 9 in.)	3.03 m (9 ft. 11 in.)	3.03 m (9 ft. 11 in.)	3.03 m (9 ft. 11 in.)	2.67 m (8 ft. 9 in.)	3.02 m (9 ft. 11 in.)	3.02 m (9 ft. 11 in.)	3.02 m (9 ft. 11 in.)
I Reach, 45-deg. Dump, Full Height	1.04 m (3 ft. 5 in.)	1.04 m (3 ft. 5 in.)	1.04 m (3 ft. 5 in.)	1.04 m (3 ft. 5 in.)	1.05 m (3 ft. 5 in.)	1.05 m (3 ft. 5 in.)	1.05 m (3 ft. 5 in.)	1.05 m (3 ft. 5 in.)
J Reach, 45-deg. Dump, 2.13-m (7 ft. 0 in.) Clearance	1.47 m (4 ft. 10 in.)	1.77 m (5 ft. 10 in.)	1.77 m (5 ft. 10 in.)	1.77 m (5 ft. 10 in.)	1.48 m (4 ft. 10 in.)	1.78 m (5 ft. 10 in.)	1.78 m (5 ft. 10 in.)	1.78 m (5 ft. 10 in.)
K Maximum Digging Depth	127 mm (5.0 in.)	127 mm (5.0 in.)	209 mm (8.2 in.)	209 mm (8.2 in.)	128 mm (5.0 in.)	128 mm (5.0 in.)	210 mm (8.3 in.)	210 mm (8.3 in.)
L Maximum Rollback at Ground Level	41 deg.	41 deg.	41 deg.	41 deg.	41 deg.	41 deg.	41 deg.	41 deg.
M Maximum Rollback, Boom Fully Raised	54 deg.	54 deg.	48 deg.	48 deg.	54 deg.	54 deg.	48 deg.	48 deg.
N Maximum Bucket Dump Angle, Fully Raised	51 deg.	51 deg.	46 deg.	46 deg.	51 deg.	51 deg.	46 deg.	46 deg.
Loader Clearance Circle, Bucket Carry Position	11.68 m (38 ft. 4 in.)	11.80 m (38 ft. 9 in.)	12.02 m (39 ft. 5 in.)	12.14 m (39 ft. 10 in.)	11.68 m (38 ft. 4 in.)	11.80 m (38 ft. 9 in.)	12.02 m (39 ft. 5 in.)	12.14 m (39 ft. 10 in.)
Specifications With Bucket With Bolt-On Edge								
Capacity, Heaped	2.1 m ³ (2.75 cu. yd.)	2.3 m ³ (3.0 cu. yd.)	2.1 m ³ (2.75 cu. yd.)	2.3 m ³ (3.0 cu. yd.)	2.1 m ³ (2.75 cu. yd.)	2.3 m ³ (3.0 cu. yd.)	2.1 m ³ (2.75 cu. yd.)	2.3 m ³ (3.0 cu. yd.)
Capacity, Struck	1.7 m ³ (2.2 cu. yd.)	2.0 m ³ (2.6 cu. yd.)	1.7 m ³ (2.2 cu. yd.)	2.0 m ³ (2.6 cu. yd.)	1.7 m ³ (2.2 cu. yd.)	2.0 m ³ (2.6 cu. yd.)	1.7 m ³ (2.2 cu. yd.)	2.0 m ³ (2.6 cu. yd.)
Bucket Weight With Bolt-On Cutting Edge	1424 kg (3,139 lb.)	1451 kg (3,199 lb.)	1424 kg (3,139 lb.)	1451 kg (3,199 lb.)	1424 kg (3,139 lb.)	1451 kg (3,199 lb.)	1424 kg (3,139 lb.)	1451 kg (3,199 lb.)
Bucket Width	2.55 m (8 ft. 4 in.)	2.69 m (8 ft. 10 in.)	2.55 m (8 ft. 4 in.)	2.69 m (8 ft. 10 in.)	2.55 m (8 ft. 4 in.)	2.69 m (8 ft. 10 in.)	2.55 m (8 ft. 4 in.)	2.69 m (8 ft. 10 in.)
Breakout Force	9015 kg (19,875 lb.)	8998 kg (19,836 lb.)	8313 kg (18,328 lb.)	8295 kg (18,288 lb.)	9015 kg (19,875 lb.)	8998 kg (19,836 lb.)	8314 kg (18,329 lb.)	8296 kg (18,290 lb.)
Tipping Load, Straight, No Tire Deflection	9911 kg (21,850 lb.)	9880 kg (21,782 lb.)	8487 kg (18,711 lb.)	8456 kg (18,642 lb.)	9957 kg (21,952 lb.)	9927 kg (21,884 lb.)	8562 kg (18,876 lb.)	8531 kg (18,807 lb.)
Tipping Load, Straight, With Tire Deflection	9375 kg (20,668 lb.)	9345 kg (20,602 lb.)	8067 kg (17,785 lb.)	8037 kg (17,719 lb.)	9429 kg (20,787 lb.)	9399 kg (20,721 lb.)	8151 kg (17,970 lb.)	8118 kg (17,897 lb.)
Tipping Load, 40-deg. Full Turn, No Tire Deflection	8515 kg (18,772 lb.)	8484 kg (18,705 lb.)	7262 kg (16,009 lb.)	7231 kg (15,941 lb.)	8577 kg (18,910 lb.)	8547 kg (18,842 lb.)	7347 kg (16,197 lb.)	7316 kg (16,129 lb.)
Tipping Load, 40-deg. Full Turn, With Tire Deflection	7827 kg (17,256 lb.)	7794 kg (17,183 lb.)	6714 kg (14,802 lb.)	6687 kg (14,742 lb.)	7902 kg (17,421 lb.)	7872 kg (17,355 lb.)	6813 kg (15,020 lb.)	6783 kg (14,954 lb.)
Rated Operating Load, 50% Full-Turn Tipping Load, No Tire Deflection (conforms to ISO 14397-1)*	4257 kg (9,386 lb.)	4242 kg (9,352 lb.)	3631 kg (8,005 lb.)	3615 kg (7,971 lb.)	4289 kg (9,455 lb.)	4273 kg (9,421 lb.)	3673 kg (8,098 lb.)	3658 kg (8,064 lb.)
Rated Operating Load, 50% Full-Turn Tipping Load, With Tire Deflection (conforms to ISO 14397-1)*	3914 kg (8,628 lb.)	3897 kg (8,591 lb.)	3357 kg (7,401 lb.)	3344 kg (7,371 lb.)	3951 kg (8,710 lb.)	3936 kg (8,677 lb.)	3407 kg (7,510 lb.)	3392 kg (7,477 lb.)
Operating Weight	13 097 kg (28,874 lb.)	13 125 kg (28,935 lb.)	13 196 kg (29,092 lb.)	13 223 kg (29,152 lb.)	13 405 kg (29,554 lb.)	13 433 kg (29,614 lb.)	13 529 kg (29,826 lb.)	13 556 kg (29,886 lb.)

Loader operating information is based on machine with identified linkage and standard equipment, John Deere PowerTech E 6068H/PowerTech PVS 6068 engine, ROPS cab, rear cast bumper/counterweight, transmission side-frame guards, bottom guards, standard tires, full fuel tank, and 79-kg (175 lb.) operator. This information is affected by changes in tires, ballast, and different attachments.

*Rated operating capacity based on Deere attachments only.

While general information, pictures, and descriptions are provided, some illustrations and text may include product options and accessories NOT AVAILABLE in all regions, and in some countries products and accessories may require modifications or additions to ensure compliance with the local regulations of those countries.

544 G-TIER

Dimensions and Specifications With Hi-Vis Coupler and Construction Forks **544 G Z-BAR / HIGH-LIFT TIER 3 / FT4**

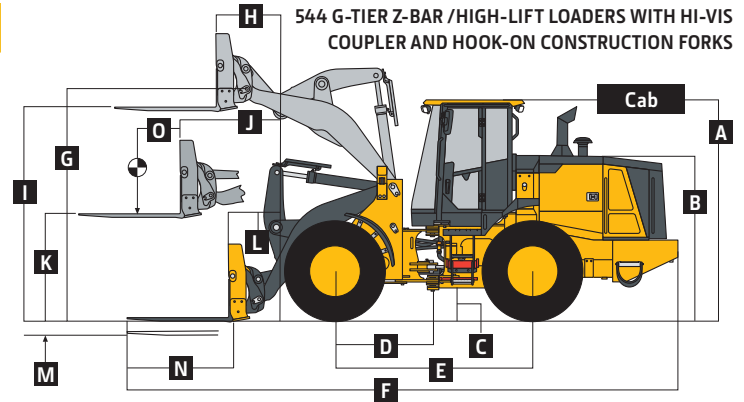

	544 G Z-Bar Tier 3	544 G High-Lift Tier 3	544 G Z-Bar FT4	544 G High-Lift FT4
Dimensions With Forks (illustration above right)	1.52-m (60 in.) tine length	1.52-m (60 in.) tine length	1.52-m (60 in.) tine length	1.52-m (60 in.) tine length
A Height to Top of Cab	3.27 m (10 ft. 9 in.)	3.27 m (10 ft. 9 in.)	3.27 m (10 ft. 9 in.)	3.27 m (10 ft. 9 in.)
B Hood Height	2.43 m (7 ft. 11 in.)	2.43 m (7 ft. 11 in.)	2.43 m (7 ft. 11 in.)	2.43 m (7 ft. 11 in.)
C Ground Clearance	0.40 m (16.1 in.)	0.40 m (16.1 in.)	0.40 m (16.1 in.)	0.40 m (16.1 in.)
D Length From Centerline to Front Axle	1.45 m (4 ft. 9 in.)	1.45 m (4 ft. 9 in.)	1.45 m (4 ft. 9 in.)	1.45 m (4 ft. 9 in.)
E Wheelbase	2.93 m (9 ft. 7 in.)	2.93 m (9 ft. 7 in.)	2.93 m (9 ft. 7 in.)	2.93 m (9 ft. 7 in.)
F Overall Length, Forks on Ground	8.42 m (27 ft. 7 in.)	8.74 m (28 ft. 8 in.)	8.42 m (27 ft. 7 in.)	8.74 m (28 ft. 8 in.)
G Height to Hinge Pin, Fully Raised	3.83 m (12 ft. 7 in.)	4.19 m (13 ft. 9 in.)	3.83 m (12 ft. 7 in.)	4.18 m (13 ft. 9 in.)
H Reach, Fully Raised	0.79 m (31.1 in.)	0.79 m (31.1 in.)	0.80 m (31.5 in.)	0.80 m (31.5 in.)
I Fork Height, Fully Raised	3.49 m (11 ft. 5 in.)	3.84 m (12 ft. 7 in.)	3.49 m (11 ft. 5 in.)	3.84 m (12 ft. 7 in.)
J Maximum Reach, Fork Level	1.58 m (5 ft. 2 in.)	1.85 m (6 ft. 1 in.)	1.59 m (5 ft. 3 in.)	1.86 m (6 ft. 1 in.)
K Fork Height, Maximum Reach	1.62 m (5 ft. 4 in.)	1.62 m (5 ft. 4 in.)	1.62 m (5 ft. 4 in.)	1.62 m (5 ft. 4 in.)
L Reach, Ground Level	1.04 m (3 ft. 5 in.)	1.36 m (4 ft. 6 in.)	1.05 m (3 ft. 5 in.)	1.37 m (4 ft. 6 in.)
M Depth Below Ground	0.12 m (5 in.)	0.20 m (8 in.)	0.12 m (5 in.)	0.20 m (8 in.)
N Tine Length	1.52 m (60 in.)	1.52 m (60 in.)	1.52 m (60 in.)	1.52 m (60 in.)
O Load Position, 50% Tine Length	0.76 m (30 in.)	0.76 m (30 in.)	0.76 m (30 in.)	0.76 m (30 in.)

Specifications With Forks

Tipping Load, Straight, No Tire Deflection	6976 kg (15,379 lb.)	6288 kg (13,863 lb.)	7008 kg (15,450 lb.)	6344 kg (13,986 lb.)
Tipping Load, Straight, With Tire Deflection	6792 kg (14,974 lb.)	6123 kg (13,499 lb.)	6828 kg (15,053 lb.)	6186 kg (13,638 lb.)
Tipping Load, 40-deg. Full Turn, No Tire Deflection	5991 kg (13,208 lb.)	5380 kg (11,861 lb.)	6035 kg (13,305 lb.)	5444 kg (12,002 lb.)
Tipping Load, 40-deg. Full Turn, With Tire Deflection	5736 kg (12,646 lb.)	5160 kg (11,376 lb.)	5790 kg (12,765 lb.)	5223 kg (11,515 lb.)
Rated Operating Load, 50% Full-Turn Tipping Load, With Tire Deflection (conforms to ISO 14397-1 and SAE J1197)*	2868 kg (6,323 lb.)	2580 kg (5,688 lb.)	2895 kg (6,382 lb.)	2612 kg (5,757 lb.)
Rated Operating Load, Rough Terrain, 60% Full-Turn Tipping Load, With Tire Deflection (conforms to EN474-3)*	3442 kg (7,587 lb.)	3096 kg (6,826 lb.)	3474 kg (7,659 lb.)	3134 kg (6,909 lb.)
Rated Operating Load, Firm and Level Ground, 80% Full-Turn Tipping Load, With Tire Deflection (conforms to EN474-3)*	4589 kg (10,117 lb.)	4128 kg (9,101 lb.)	4632 kg (10,212 lb.)	4178 kg (9,212 lb.)
Operating Weight	12 993 kg (28,646 lb.)	13 092 kg (28,863 lb.)	13 299 kg (29,320 lb.)	13 422 kg (29,591 lb.)

Loader operating information is based on machine with identified linkage and standard equipment, John Deere PowerTech E 6068H/PowerTech PVS 6068 engine, ROPS cab, rear cast bumper/counterweight, transmission side-frame guards, bottom guards, standard tires, full fuel tank, and 79-kg (175 lb.) operator. This information is affected by changes in tires, ballast, and different attachments.

*Rated operating capacity based on Deere attachments only.

544 G Z-BAR / HIGH-LIFT TIER 3 Adjustments to Operating Weights and Tipping Loads With Buckets

Adjustments to operating weights, tipping loads, and tires are based on Z-Bar machine with pin-on 2.3-m³ (3.0 cu. yd.) general-purpose bucket with bolt-on cutting edge, ROPS cab, rear cast bumper/counterweight, transmission side-frame guards, bottom guards, standard tires, full fuel tank, and 79-kg (175 lb.) operator*

Add (+) or deduct (-) kg (lb.) as indicated	Tipping Load,		Tread Width	Width Over Tires	Vertical Height
	Straight	40-deg. Full Turn			
for loaders with 3-piece rims					
MAXAM 20.5 R 25, 2 Stars L-3	+ 274 kg (+ 604 lb.)	+ 207 kg (+ 457 lb.)	+ 183 kg (+ 403 lb.)	0 mm (0 in.)	- 10 mm (- 0.4 in.)
MAXAM 20.5 R 25, 2 Stars L-2	+ 274 kg (+ 604 lb.)	+ 199 kg (+ 438 lb.)	+ 175 kg (+ 387 lb.)	0 mm (0 in.)	- 10 mm (- 0.4 in.)

*May change based on vehicle configuration, weight, or tire-pressure adjustments.

544 G Z-BAR / HIGH-LIFT FT4 Adjustments to Operating Weights and Tipping Loads With Buckets

Adjustments to operating weights, tipping loads, and tires are based on Z-Bar machine with pin-on 2.3-m³ (3.0 cu. yd.) general-purpose bucket with bolt-on cutting edge, ROPS cab, rear cast bumper/counterweight, transmission side-frame guards, bottom guards, standard tires, full fuel tank, and 79-kg (175 lb.) operator*

Add (+) or deduct (-) kg (lb.) as indicated	Tipping Load,		Tread Width	Width Over Tires	Vertical Height
	Straight	40-deg. Full Turn			
for loaders with 3-piece rims					
MAXAM 20.5 R 25, 2 Stars L-3	+ 72 kg (+ 159 lb.)	+ 56 kg (+ 124 lb.)	+ 50 kg (+ 110 lb.)	0 mm (0 in.)	+ 2 mm (+ 0.1 in.)
MAXAM 20.5 R 25, 2 Stars L-2	+ 72 kg (+ 159 lb.)	+ 48 kg (+ 106 lb.)	+ 42 kg (+ 94 lb.)	0 mm (0 in.)	+ 2 mm (+ 0.1 in.)

*May change based on vehicle configuration, weight, or tire-pressure adjustments.

While general information, pictures, and descriptions are provided, some illustrations and text may include product options and accessories NOT AVAILABLE in all regions, and in some countries products and accessories may require modifications or additions to ensure compliance with the local regulations of those countries.

544 G Z-BAR / HIGH-LIFT TIER 3 / FT4 Bucket Selection Guides*

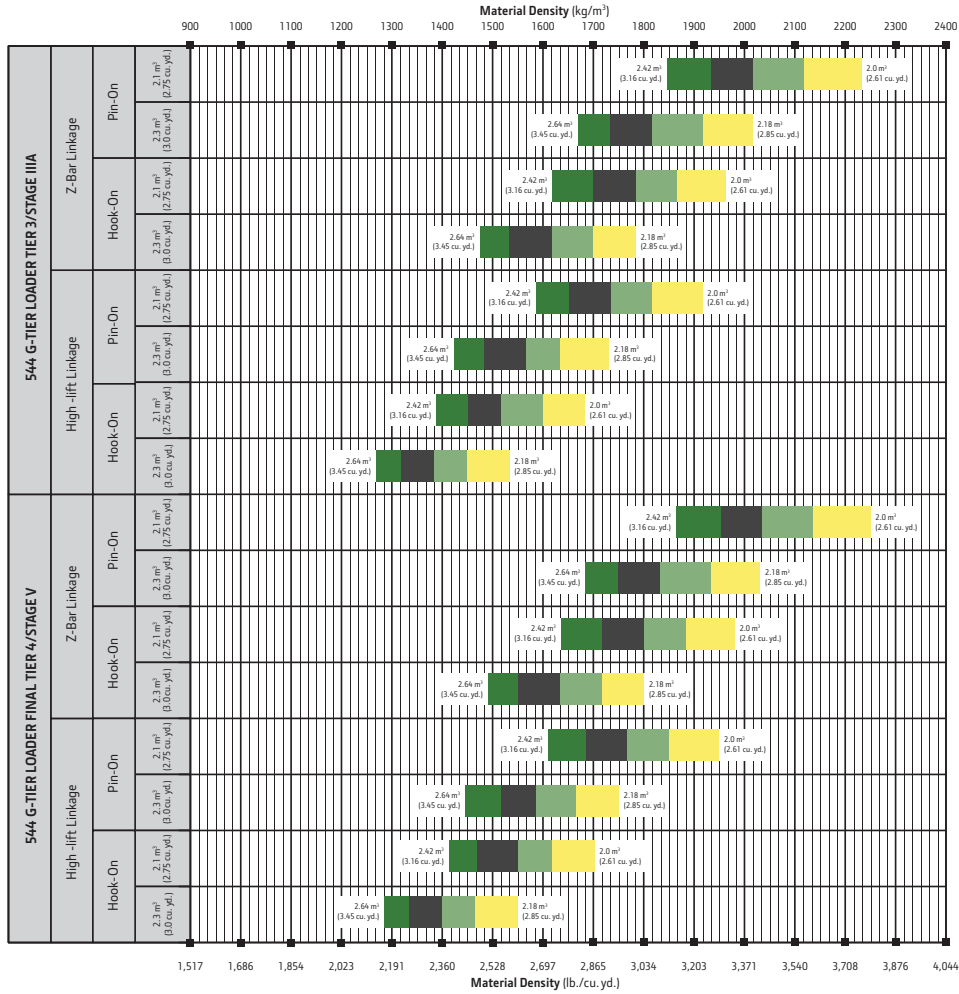

LOOSE MATERIALS		kg/m ³	lb./cu. yd.	LOOSE MATERIALS		kg/m ³	lb./cu. yd.
Chips, pulpwood	288	486	Limestone, coarse, sized	1570	2,646		
Cinders (coal, ashes, clinkers)	673	1,134	Limestone, mixed sizes	1682	2,835		
Clay and gravel, dry	1602	2,700	Limestone, pulverized or crushed	1362	2,295		
Clay, compact, solid	1746	2,943	Sand, damp	2083	3,510		
Clay, dry in lump loose	1009	1,701	Sand, dry	1762	2,970		
Clay, excavated in water	1282	2,160	Sand, voids, full of water	2083	3,510		
Coal, anthracite, broken, loose	865	1,458	Sandstone, quarried	1314	2,214		
Coal, bituminous, moderately wet	801	1,350	Shale, broken crushed	1362	2,295		
Earth, common loam, dry	1218	2,052	Slag, furnace granulated	1955	3,294		
Earth, mud, packed	1843	3,105	Stone or gravel, 37.5 to 87.5-mm				
Granite, broken	1538	2,592	(1.5 to 3.5 in.) size	1442	2,430		
Gypsum	2275	3,834	Stone or gravel, 18.75-mm (0.75 in.) size	1602	2,700		

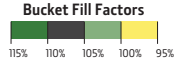

Additional equipment

Key: ● Standard ▲ Optional or special
See your John Deere dealer for further information.

544 G Engine

- Wet-sleeve cylinder liners
- Programmable auto-idle and auto shutdown
- Starter excessive-cranking protection
- Automatic engine cool-down timer
- Automatic derating for exceeded system temperatures
- Serpentine drive belt for automatic tensioner
- Electrical fuel-priming pump
- Dual-stage fuel filter and water separator
- 500-hour vertical spin-on oil filter
- Automatic glow plugs for cold start
- ▲ Engine-block heater (recommended for cold starts below -23 deg. C [-10 deg. F])
- ▲ Centrifugal engine air pre-cleaner

Powertrain

- Clutch cutoff with 3 operator settings: Level ground, small slope, or steep slope
- Clutch calibration engaged from monitor
- 2,000-hour vertical spin-on transmission filter
- Transmission fill tube and sight gauge
- 5-speed transmission with non-lockup torque converter
- ▲ Front locking differential
- Brake retractors and adjusters

Cooling System

- Isolated from engine compartment
- Engine radiator
- Engine oil cooler
- Hydraulic oil cooler (oil to air)
- Transmission oil cooler (oil to air)
- Charge air cooler (air to air)
- Coolant recovery tank
- Antifreeze, -47 deg. C (-52 deg. F)
- Cool-on-demand, hydraulically driven fan
- Enclosed fan safety guard
- ▲ Automatic reversing fan drive

Hydraulics

- Pilot hydraulic controls
- Automatic return-to-dig bucket positioner
- In-cab adjustable automatic boom-height kickout/return to carry
- Reservoir with sight gauge and fill strainer
- Hydraulic diagnostic ports
- 4,000-hour in-tank filter
- 2 function — joystick with F-N-R
- ▲ 2 function — 2-lever fingertip controls and steering column F-N-R
- ▲ 3 function — joystick with F-N-R and 3rd-function auxiliary lever
- ▲ 4 function — joystick with F-N-R and 3rd- and 4th-function auxiliary levers

544 G Hydraulics (continued)

- ▲ Ride control, automatic with monitor-adjustable speed settings
- ▲ Hydraulic control system for quick-coupler locking pins
- ▲ Hydrau™ XR cold-temperature hydraulic fluid recommended below -25 deg. C (-13 deg. F)

Steering Systems

- Conventional steering wheel with spinner knob
- ▲ Secondary steering

Electrical

- Solid-state electrical power-distribution system
- Lockable master electrical-disconnect switch
- Battery-terminal safety covers
- Pre-wired for beacon/strobe light
- ▲ Rotary beacon
- Lights: Halogen driving lights (2) / Front (2) and rear cab (2) / Halogen front turn signals and flashers / LED stop- and taillights
- Horn, electric
- Reverse warning alarm
- Multifunction/multi-language 127-mm (5 in.) LCD color monitor includes: Digital instruments — Analog display (engine coolant temperature and transmission oil temperature) / Digital display (engine rpm, transmission gear/direction indicator, hour meter, fuel level, diesel exhaust fluid (DEF) level, speedometer, and average fuel consumption)
- Indicator lights: Standard and selected options / Amber caution and red stop
- Operator-warning messages
- Built-in diagnostics: Diagnostic-code details / Sensor values / Calibrations / Individual circuit tester
- Radio ready
- ▲ AM/FM radio
- 24- to 12-volt, 15-amp converter and cab power port

Operator's Station

- Cab with air conditioning/heater (ROPS/FOPS Level 2, isolation mounted)
- Keyless start with multiple security modes
- Sealed-switch module with function indicators
- Seat with headrest extension, fabric cover, and adjustable mechanical suspension
- ▲ Seat with headrest extension, fabric cover, and adjustable air suspension
- High-visibility, bright-orange seat belt, 76 mm (3 in.), with retractor
- Cup holder
- Coat hook

544 G Operator's Station (continued)

- Dome and reading light
- Rubber floor mat
- Tilt steering column
- Operator's manual storage compartment
- Outside (2) and inside (1) rearview mirrors
- ▲ Heated outside mirrors with convex lens
- Left-side operator-station access
- Slip-resistant steps and ergonomic handholds
- Pull-down front sun visor
- Front and rear intermittent windshield wipers and washers
- Rearview camera
- ▲ Fire extinguisher bracket

Loader Linkage

- Z-Bar loader linkage
- ▲ High-lift linkage

Buckets and Attachments

- ▲ Full line of Deere pin-on buckets, coupler buckets, and forks
- ▲ Hi-Vis hydraulic coupler that accepts Euro-pattern attachments (ISO)
- ▲ Full line of Deere hook-on buckets and forks
- ▲ John Deere hydraulic coupler that accepts JRB-pattern attachments

Overall Vehicle

- JDLink™ wireless communication system (available in specific countries; see your dealer for details)
- Front and rear tie-downs
- Rear counterweight with hitch and locking pin
- Articulation locking bar
- Loader boom service locking bar
- 40-deg. steering articulation to each side with rubber-cushion stops on frame
- Vandal protection with lockable engine enclosures, counterweight compartments, and filler access for radiator/fuel/DEF/hydraulic transmission
- Left-side service steps and handholds
- Fuel-tank fill strainer
- Ground-level fuel and DEF fill
- Same-side ground-level daily servicing
- 20.5R25 radial tires on 3-piece rims
- ▲ 20.5R25 bias tires on 3-piece rims
- ▲ 20.5R25 radial snow tires on 3-piece rims
- Fenders, front narrow
- ▲ Fenders, front and rear full width
- ▲ Transmission side-frame and bottom guards
- ▲ Lift eyes
- ▲ License-plate bracket and light

While general information, pictures, and descriptions are provided, some illustrations and text may include product options and accessories NOT AVAILABLE in all regions, and in some countries products and accessories may require modifications or additions to ensure compliance with the local regulations of those countries.

Net engine power is with standard equipment including air cleaner, exhaust system, alternator, and cooling fan at test conditions per ISO 9249. No derating is required up to 3050-m (10,000 ft.) altitude. Specifications and design subject to change without notice. Specifications with the exception of bucket capacity are in accordance with all applicable ISO standards. Except where otherwise noted, these specifications are based on a unit with applicable linkage and standard equipment, ROPS cab, rear cast bumper/counterweight, transmission side-frame guards, bottom guards, standard tires, full fuel tank, and 79-kg (175 lb.) operator.



MWS44GAP (22-08)

 **JOHN DEERE**